

A major benefit of retrofits is the common user interface shared with new testing systems.  
Source: Instron

# To Retrofit or Not to Retrofit:

## WHEN YOUR UNIVERSAL TESTING SYSTEM GETS OLD

It is possible to retrofit almost any older testing system. The question is whether the investment is worthwhile.

BY FRANK LIO AND PAUL MARTIN

**U**niversal Testing Machines (UTMs) are reliable workhorses—they can run hundreds of tests each day, seven days a week, sustaining the energy from test specimens breaking at loads up to 5 kN, 50 kN, even 600 kN and beyond. However, just like a real workhorse with years or decades of service, they will eventually get old, wear down, and not be as reliable or perform as well as newer alternatives—but do you put it out to pasture? Or can you update it with a

retrofit and keep it reliably running—perhaps even better than ever?

### UNDERSTANDING THE SYSTEM COMPONENTS

UTMs have been in existence for more than 80 years, with the most common being electromechanical testing systems. Used for performing tensile, compression, flexural (bending), and component tests, the design of these systems can be separated into two major parts: the frame and the controller.

The testing frame is the bulk of the mechanical portion of the system. The load frame typically has twin columns with rotating lead screws, which move a crosshead vertically up and down. More robust systems include guide columns to provide structural stiffness and improve alignment. The load transducer (load cell) is attached to the moving crosshead or base. Grips, platens, or other fixtures are attached to both the load cell and the base to complete the test load string. An encoder is typically used to read the distance that the moving crosshead travels during the test. Other transducers, such as extensometers or LVDTs, may also be used to measure the actual displacement for the specimen or component being tested.

The controller can be considered the “brains” of the system. The controller is responsible for monitoring and controlling the frame and transducers in conjunction with other accessories such as temperature chambers and furnaces. A controller may also be coupled with a computer for control with predefined test methods, data collection, analysis, and reporting.

### WHEN GOOD PARTS GO BAD

At some point, system components fail. Critical components that are used continuously include the power amplifier and motor. The power amplifier is the main driver in the testing system, drawing considerable power and driving the motor. Power amplifiers are a common component that can fail after 10 to 15 years of usage—and in many cases, the original supplier cannot supply the original component model. One of the major problems facing testing system manufacturers is having components being obsoleted by their OEM suppliers at an increasingly faster rate, particularly electronic parts such as processor chips or displays. Options may include repair or using refurbished parts, a fully compatible part alternative may be readily available, or an entirely new part may need to be designed and tested as a replacement. While most testing system manufacturers strive to keep older systems running, it does reach a point when all such options may be unfeasible for both the manufacturer and customer based on system downtime and cost.

### WHEN TO CONSIDER A RETROFIT

A retrofit can be simply defined as an upgrade to an older testing system. In some cases, a retrofit may consist of only removing the controller portion and replacing it with a current generation version. More extensive retrofits may involve replacing critical components prone to failure or obsoleted such as motors or power amplifiers. Other important items to consider in a retrofit are whether the upgrade includes bringing the upgraded system to current industry standards. Most retrofits today include new software and a computer with predefined test methods to automate much of the testing process, data analysis, and reporting.



This is an example of an Instron Model 4505 produced 25 years ago retrofitted with new electronics, control panel, and software, completed in one day at a customer site. *Source: Instron*



Older testing systems can now use the latest software to display test curves, calculated results, video capture of test, and data points. *Source: Instron*

Many users consider a system retrofit when the system controller becomes increasingly outdated compared to current industry standards or is incompatible with newer accessories. For example, a data acquisition rate of 20 points per second was considered “fast” twenty years ago. Current systems can acquire test data upwards to 2.5 KHz—providing a truer definition of the test curve profile, uncover-

ing additional points of interest, and providing more accurate test results. Many older controllers are not compatible with newer computers with the latest operating systems.

Older controllers may not have the processing power and response time required to test to some of the newer test standards. For example, ISO 6892-1:2009 “Metallic Materials – Tensile Testing” and ASTM E8-15 “Standard

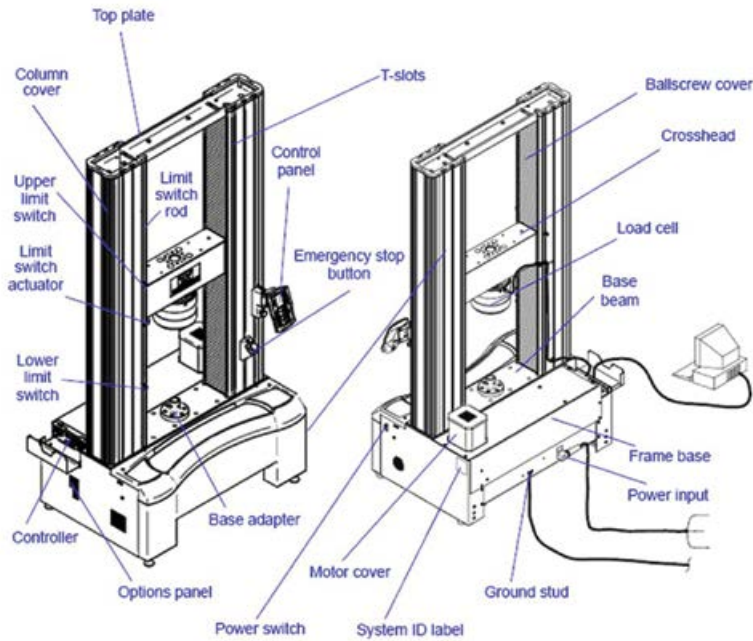

Components of a Universal Testing System. Source: Instron

Test Methods for Tension Testing of Metallic Materials” specify very restrictive strain rates and tolerances for closed-loop strain rate control that are often beyond the capability of older controllers and software.

A retrofit is an economical way to refresh an older testing frame with the same, common test interface and operation as other newer testing systems in the same laboratory—without having to buy a brand new testing machine. Laboratory operators can then operate all their testing systems in the same manner—therefore improving efficiency, minimizing operator training, reducing user errors, and increasing results consistency. Existing load cells, grips, and other accessories can be retained and used to save on the original investment.

**THERE IS NO “ONE SIZE FITS ALL” FOR RETROFITS**

There are a number of risks and benefits when considering a retrofit. Be aware that there is no such thing as a single retrofit solution that works for every testing system, regardless of the manufacturer.

First consider what is included with the retrofit. For older systems, parts that are at risk to fail within the near or medium term, such as power amplifiers, should be included. Safety is also

a major consideration. Look for safety components, such as new emergency stops, that meet the latest industry requirements. In addition, ensure that existing safety features are not disabled or removed when the system has been retrofitted. An example is the secondary or second-level crosshead limit stops that protect the system’s moving crosshead from traveling too far in either direction and act as back-up should the first-level limits fail.

Retrofit packages should be designed to fully match the dynamic performance of the original testing system.

A replacement power amplifier or motor must be properly sized for the current and voltage. An undersized power amplifier or motor will result in underperformance; the testing system will not reach full load capacity or maximum test speeds and perhaps fail prematurely due to overload. Oversized components will work, but this design inefficiency means that you will be paying for more than what you ever need.

Most critical, the control system must be well-tuned for stability and optimal performance, ensuring that the system command and feedback loop is at its most ideal setting. Tuning requires knowing and inputting the correct PID control parameters (proportional band/gain, integral gain/reset, derivative gain/rate). Improperly tuned systems result in poor performance at best and serious safety concerns at worst. Issues include inaccurate test speeds, inaccurate test read-outs, motor oscillations, machine instability, vibrations, abrupt and sudden crosshead movements, overshooting test limits, machine not stopping promptly when required, and more.

Certainly, there are third-parties that offer after-market retrofits, but in this regard, the original system manufacturer would recognize the optimal parameters and inherent safety features that they engineered into the original product. As an example, a third-party doing a retrofit might remove the system’s original covers or enclosures to fit their new retrofit components—without realizing that the discarded articles were actually part of the RF shielding (for blocking the effects of radio frequency interference).

In addition, existing transducers, such as load cells and extensometers, must be made electrically compatible via adapters to connect to the new controller and electrically for proper calibration, balancing, and read-out.

**TECH TIPS**

- » Larger capacity floor model frames tend to be the most suitable candidates for retrofits due to the cost of a new system and accessories.
- » Table model frames may not be such a straightforward decision, particularly with the choice of new frames on the market.
- » A laboratory that originally purchased a 5 kN frame may find a small 2 kN single column tester a better replacement if they have never tested beyond 2 kN or if they prefer the smaller machine footprint.

**INSTALLING A RETROFIT**

Per ASTM E4 and ISO 9513, a retrofitted system must be verified prior to use due to the new replacement parts and modifications. ASTM E4 “Standard Practices for Force Verification of Testing Machines” states

“Testing machines shall be verified immediately after repairs (this includes new or replacement parts, or mechanical or electrical adjustments) that may in any way affect the operation of the weighing system or the values displayed.”

Thus, it is worth considering a retrofit provider who can complete the retrofit, fine-tune the settings for the system, and also provide all required services including verifying the load cells, extensometers, displacement, and speed. Since ASTM E4 also stipulates that a relocated machine requires verification, one may want to consider a retrofit that can be completed at the customer site, which also saves significant money and time from packing and shipping a potentially large system back and forth.

Most retrofits on standard universal testing systems should be completed in one to two days, including the verification of all transducers.

### WHEN NOT TO CONSIDER A RETROFIT

Not every testing system is a good candidate for retrofitting. A retrofit will not replace every part of an existing system. Typically, the rotating lead screws, gear boxes, and clutches are parts that tend to be very reliable and do not need to be replaced. However, should they fail, they are very expensive to replace—not just in terms of parts cost, but also the cost of the service labor and downtime. The performance of the frame may also not improve beyond what is physically there. For example, no matter how good the new controller electronics are, you may not get a better load accuracy range beyond what the original load cell can provide. Newer accessories designed for more modern testing frames may also require custom mounting to fit in older frames.

Just like an automobile, there is a point when it is less expensive and worthwhile to acquire an entirely new replacement versus replacing or repairing every possible part.

### TO RETROFIT OR NOT TO RETROFIT

Of course, it is possible to retrofit almost any older testing system. The question is whether the investment is worthwhile. Ask what components are being replaced or retained. Question the life expectancy of the retained parts and the options and costs should they fail. Consider whether newer accessories or software can be readily used.

Larger capacity floor model frames tend to be the most suitable candidates for retrofits due to the cost of a new sys-



An Instron 5900 retrofit control panel with LCD live displays and controls is shown here. Source: Instron

tem and accessories. Table model frames may not be such a straightforward decision, particularly with the choice of new frames on the market. A laboratory that originally purchased a 5 kN frame may find a small 2 kN single column tester a better replacement if they have never tested beyond 2 kN or if they prefer the smaller machine footprint (since lab space can be a scarce commodity).

### KNOW THE PROS, CONS, AND RISKS OF A RETROFIT

#### Pros

- Retain much of your original investment: frame, load cells, accessories
- Can cost less than a new testing system
- Is considered a maintenance budget item instead of capital equipment in some organizations
- Increases life span and reliability by replacing commonly failing parts
- Can improve certain aspects of the original testing system, e.g. higher data acquisition rates, intelligent data logging, and test automation
- Allows use of newer software and accessories, e.g. non-contacting video extensometers

#### Cons

- May not cost significantly less than a new testing system particularly

for smaller single column or table model frames

- May not cost significantly less than a new system once service labor becomes a factor
- May not replace every possible part at risk of failure; remaining parts may be very costly or cost-prohibitive to replace if they do fail
- May not be readily compatible with all newer accessories, requiring custom mounting, etc.

#### Risks

- Poor tuning of the testing system leads to poor or worst performance, e.g. crosshead travel overshoots, sudden movements, system vibrations, and inaccurate test readouts
- Replacement parts are not specifically designed for use with the particular test frame; an undersized power amplifier or motor can result in the testing system not being capable of reaching the original load capacity or full-speed range
- Original safety features are removed or disabled, e.g. second level limits **Q**

*Frank Lio is the business team product support manager and Paul Martin is the engineering technical lead at Instron. For more information, email [frank\\_lio@instron.com](mailto:frank_lio@instron.com) or [paul\\_martin@instron.com](mailto:paul_martin@instron.com) or visit [www.instron.com](http://www.instron.com).*