

# 100 and 150kN Wedge Grips (Cat. nos. 2716 / 2736)

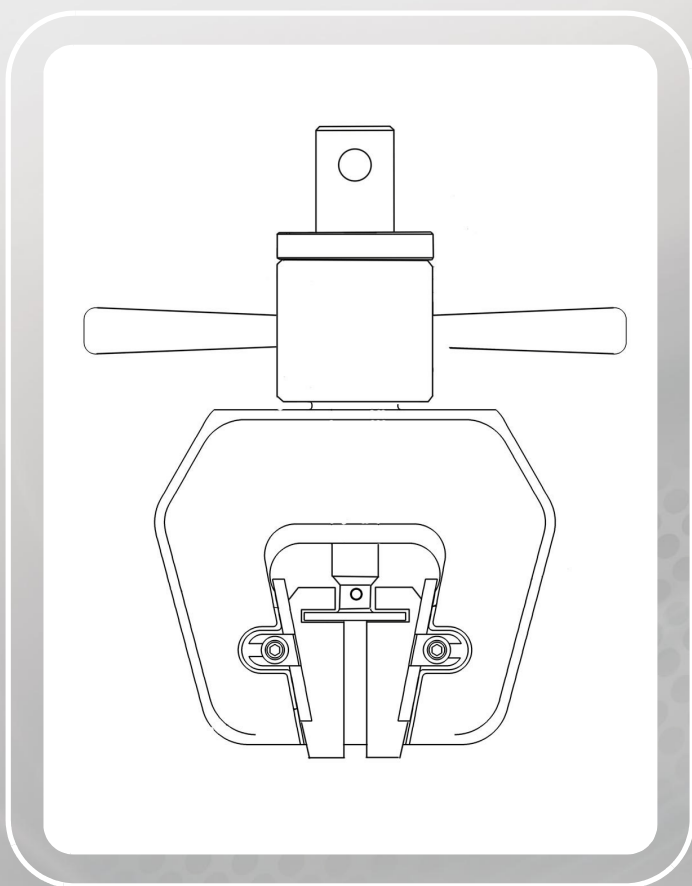

## **Electromagnetic Compatibility**

Where applicable, this equipment is designed to comply with International Electromagnetic Compatibility (EMC) standards.

To ensure reproduction of this EMC performance, connect this equipment to a low impedance ground connection. Typical suitable connections are a ground spike or the steel frame of a building.

---

## **Proprietary Rights Notice**

This document and the information that it contains are the property of Illinois Tool Works Inc. (ITW). Rights to duplicate or otherwise copy this document and rights to disclose the document and the information that it contains to others and the right to use the information contained therein may be acquired only by written permission signed by a duly authorized officer of ITW.

---

## **Trademarks**

Instron<sup>®</sup> is a registered trademark of Illinois Tool Works Inc. (ITW). Other names, logos, icons and marks identifying Instron products and services referenced herein are trademarks of ITW and may not be used without the prior written permission of ITW.

Other product and company names listed are trademarks or trade names of their respective companies.

---

## **Original Instructions**

**Copyright © 2006 Illinois Tool Works Inc. All rights reserved. All of the specifications shown in this document are subject to change without notice.**

---

### **Worldwide Headquarters**

Instron  
825 University Avenue  
Norwood, MA 02062-2643  
United States of America

### **European Headquarters**

Instron  
Coronation Road  
High Wycombe, Bucks HP12 3SY  
United Kingdom

### **Industrial Products Group**

Instron  
900 Liberty Street  
Grove City, PA 16127  
United States of America

# General Safety Precautions



Materials testing systems are potentially hazardous.

Materials testing involves inherent hazards from high forces, rapid motions, and stored energy. You must be aware of all moving and operating components in the testing system that are potentially hazardous, particularly force actuators or a moving crosshead.

Carefully read all relevant manuals and observe all Warnings and Cautions. The term Warning is used where a hazard may lead to injury or death. The term Caution is used where a hazard may lead to damage to equipment or to loss of data.

Instron products, to the best of its knowledge, comply with various national and international safety standards, in as much as they apply to materials and structural testing. We certify that our products comply with all relevant EU directives (CE mark).

Because of the wide range of applications with which our instruments are used, and over which we have no control, additional protection devices and operating procedures may be necessary due to specific accident prevention regulations, safety regulations, further EEA directives or locally valid regulations. The extent of our delivery regarding protective devices is defined in your initial sales quotation. We are thus free of liability in this respect.

At your request, we will gladly provide advice and quotations for additional safety devices such as protective shielding, warning signs or methods of restricting access to the equipment.

The following pages detail various general warnings that you must heed at all times while using materials testing equipment. You will find more specific Warnings and Cautions in the text whenever a potential hazard exists.

Your best safety precautions are to gain a thorough understanding of the equipment by reading your instruction manuals and to always use good judgement.

It is our strong recommendation that you should carry out your own product safety risk assessment.

## Warnings

---



**Hazard - Press the Emergency Stop button whenever you consider that an unsafe condition exists.**

The Emergency Stop button removes hydraulic power or electrical drive from the testing system and brings the hazardous elements of the system to a stop as quickly as possible. It does not isolate the system from electrical power, other means are provided to disconnect the electrical supply. Whenever you consider that safety may be compromised, stop the test using the Emergency Stop button. Investigate and resolve the situation that caused the use of the Emergency Stop button before you reset it.



**Flying Debris Hazard - Make sure that test specimens are installed correctly in grips or fixtures in order to eliminate stresses that can cause breakage of grip jaws or fixture components.**

Incorrect installation of test specimens creates stresses in grip jaws or fixture components that can result in breakage of these components. The high energies involved can cause the broken parts to be projected forcefully some distance from the test area. Install specimens in the center of the grip jaws in line with the load path. Insert specimens into the jaws by at least the amount recommended in your grip documentation. This amount can vary between 66% to 100% insertion depth; refer to supplied instructions for your specific grips. Use any centering and alignment devices provided.



**Hazard - Protect electrical cables from damage and inadvertent disconnection.**

The loss of controlling and feedback signals that can result from a disconnected or damaged cable causes an open loop condition that may drive the actuator or crosshead rapidly to its extremes of motion. Protect all electrical cables, particularly transducer cables, from damage. Never route cables across the floor without protection, nor suspend cables overhead under excessive strain. Use padding to avoid chafing where cables are routed around corners or through wall openings.

## Warnings

---



### **High/Low Temperature Hazard - Wear protective clothing when handling equipment at extremes of temperature.**

Materials testing is often carried out at non-ambient temperatures using ovens, furnaces or cryogenic chambers. Extreme temperature means an operating temperature exceeding 60 °C (140 °F) or below 0 °C (32 °F). You must use protective clothing, such as gloves, when handling equipment at these temperatures. Display a warning notice concerning low or high temperature operation whenever temperature control equipment is in use. You should note that the hazard from extreme temperature can extend beyond the immediate area of the test.



### **Crush Hazard - Take care when installing or removing a specimen, assembly, structure, or load string component.**

Installation or removal of a specimen, assembly, structure, or load string component involves working inside the hazard area between the grips or fixtures. When working in this area, ensure that other personnel cannot operate any of the system controls. Keep clear of the jaws of a grip or fixture at all times. Keep clear of the hazard area between the grips or fixtures during actuator or crosshead movement. Ensure that all actuator or crosshead movements necessary for installation or removal are slow and, where possible, at a low force setting.



### **Hazard - Do not place a testing system off-line from computer control without first ensuring that no actuator or crosshead movement will occur upon transfer to manual control.**

The actuator or crosshead will immediately respond to manual control settings when the system is placed off-line from computer control. Before transferring to manual control, make sure that the control settings are such that unexpected actuator or crosshead movement cannot occur.



### **Robotic Motion Hazard - Keep clear of the operating envelope of a robotic device unless the device is de-activated.**

The robot in an automated testing system presents a hazard because its movements are hard to predict. The robot can go instantly from a waiting state to high speed operation in several axes of motion. During system operation, keep away from the operating envelope of the robot. De-activate the robot before entering the envelope for any purpose, such as reloading the specimen magazine.

## Warnings

---

---



**Hazard - Set the appropriate limits before performing loop tuning or running waveforms or tests.**

Operational limits are included within your testing system to suspend motion or shut off the system when upper and/or lower bounds of actuator or crosshead travel, or force or strain, are reached during testing. Correct setting of operational limits by the operator, prior to testing, will reduce the risk of damage to test article and system and associated hazard to the operator.



**Electrical Hazard - Disconnect the electrical power supply before removing the covers to electrical equipment.**

Disconnect equipment from the electrical power supply before removing any electrical safety covers or replacing fuses. Do not reconnect the power source while the covers are removed. Refit covers as soon as possible.



**Rotating Machinery Hazard - Disconnect power supplies before removing the covers to rotating machinery.**

Disconnect equipment from all power supplies before removing any cover which gives access to rotating machinery. Do not reconnect any power supply while the covers are removed unless you are specifically instructed to do so in the manual. If the equipment needs to be operated to perform maintenance tasks with the covers removed, ensure that all loose clothing, long hair, etc. is tied back. Refit covers as soon as possible.



**Hazard - Shut down the hydraulic power supply and discharge hydraulic pressure before disconnection of any hydraulic fluid coupling.**

Do not disconnect any hydraulic coupling without first shutting down the hydraulic power supply and discharging stored pressure to zero. Tie down or otherwise secure all pressurized hoses to prevent movement during system operation and to prevent the hose from whipping about in the event of a rupture.



**Hazard - Shut off the supply of compressed gas and discharge residual gas pressure before you disconnect any compressed gas coupling.**

Do not release gas connections without first disconnecting the gas supply and discharging any residual pressure to zero.

## Warnings

---



**Explosion Hazard - Wear eye protection and use protective shields or screens whenever any possibility exists of a hazard from the failure of a specimen, assembly or structure under test.**



Wear eye protection and use protective shields or screens whenever a risk of injury to operators and observers exists from the failure of a test specimen, assembly or structure, particularly where explosive disintegration may occur. Due to the wide range of specimen materials, assemblies or structures that may be tested, any hazard resulting from the failure of a test specimen, assembly or structure is entirely the responsibility of the owner and the user of the equipment.



**Hazard - Ensure components of the load string are correctly pre-loaded to minimize the risk of fatigue failure.**

Dynamic systems, especially where load reversals through zero are occurring, are at risk of fatigue cracks developing if components of the load string are not correctly pre-loaded to one another. Apply the specified torque to all load string fasteners and the correct setting to wedge washers or spiral washers. Visually inspect highly stressed components such as grips and threaded adapters prior to every fatigue test for signs of wear or fatigue damage.





## Table of Contents

<b>Chapter 1: Introduction</b> .....	<b>11</b>
Purpose .....	11
Description .....	14
Components .....	14
Functional .....	15
<b>Chapter 2: Specifications</b> .....	<b>17</b>
Grip Specifications .....	17
Series 2716 Grips .....	17
Series 2736 Grips .....	18
Jaw faces .....	18
<b>Chapter 3: Installation</b> .....	<b>21</b>
Attachment Methods .....	21
Installing the Grips .....	22
Checklist .....	22
Procedures .....	22
Replacing Jaw faces .....	23
Equipment .....	23
Procedure .....	23
<b>Chapter 4: Operation</b> .....	<b>25</b>
Installing a Specimen .....	25
Checklist .....	26
Procedure .....	26
Removing a Specimen .....	27
Checklist .....	27
Procedure .....	27
<b>Chapter 5: Maintenance</b> .....	<b>29</b>
Cleaning and Lubrication .....	29

Checklist .....	29
Shear Pin Replacement .....	30
Troubleshooting .....	30
<b>Chapter 6: Parts.....</b>	<b>33</b>
Replaceable Parts .....	33
Ancillary Parts.....	34

# Chapter 1

## Introduction

This chapter introduces you to the low capacity (24.5 kN to 147 kN [5000 lb to 30000 lb]) Series 2716 and 2736 wedge action grips and describes the grip components. Illustrations and text detail the grip components and their function.

---

• Purpose .....	11
• Description.....	14

---

### Purpose

Instron Series 2716 and 2736 wedge action grips hold a test specimen between a stationary load frame member and a force producing crosshead or actuator. [Figure 1](#) and [Figure 2](#) illustrates the grips and their components.

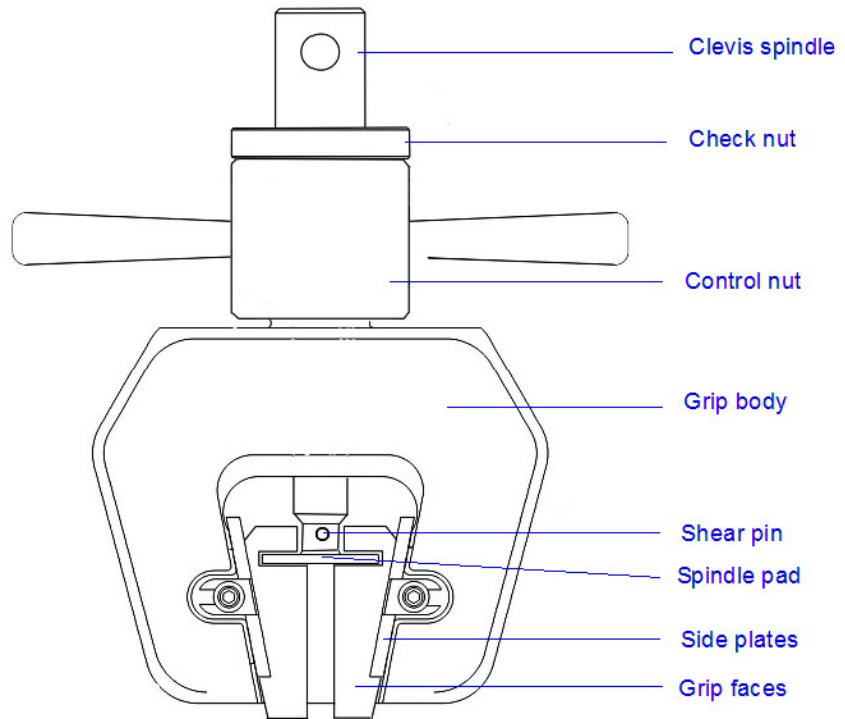

Figure 1. Typical Wedge Grip (Front)

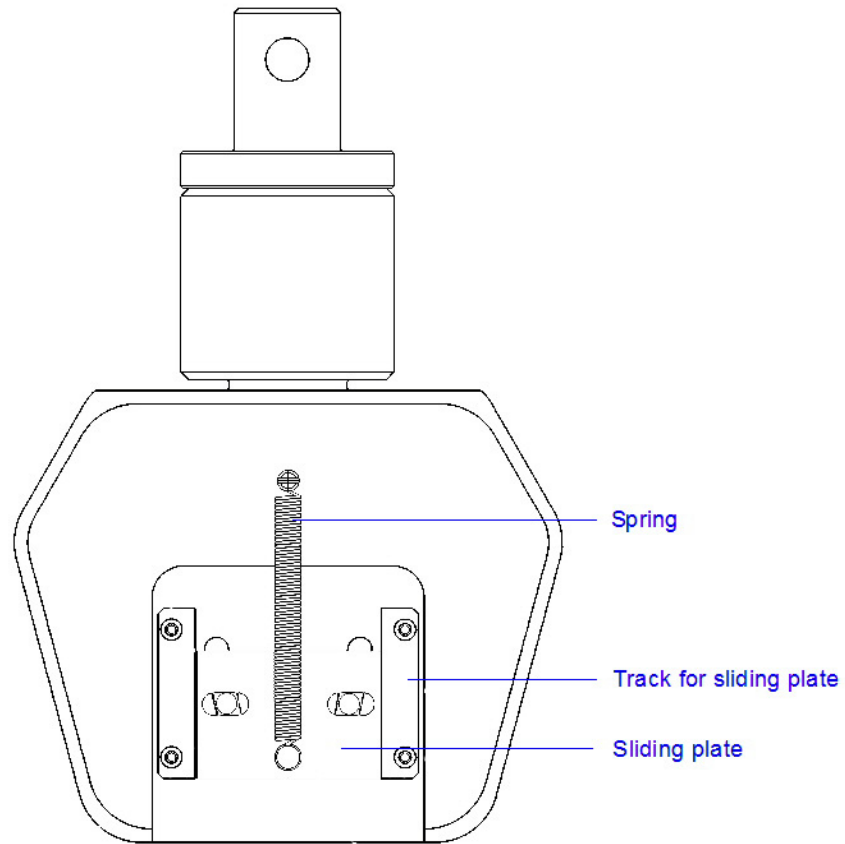

Figure 2. Typical Wedge Grip (Rear)

The grips cover a wide range of common applications in materials testing. The two series are similar, with the principal difference being that the series 2736 grips are rated for high temperature use and configured with handles that facilitate their use in high-temperature cabinets.

The grips are for static tensile testing only. The wedge action design lets the jaw faces tighten onto a specimen without altering the vertical position of the faces in relation to the specimen, letting you install a test specimen without exerting a tensile load on it while tightening the grips. A compressive test load eliminates any gripping force and causes the specimen to slip from the grips.

The open front design of the grip lets you change the jaw faces to accommodate flat, round or different size specimens.

## Description

### Components

The major grip components are the body, control mechanism, and jaw faces.

#### Body

The machined alloy-steel body has a vertical center bore with an integral threaded stud extending away from the body. A control nut threads on the stud and a spindle passes through the bore.

The grip body has a machined open cavity. Each side of the cavity tapers toward the open end of the body. The jaw faces have a matching taper such that as the faces slide toward the open end of the cavity, they are forced together and thus provide a gripping force on a specimen.

Side plates, screwed to the front of the grip body, retain the jaw faces within the cavity. On the rear of the body, a spring-loaded plate slides in tracks screwed to the body. Pins in the grip jaws extend through slots in the plate. The spring force on the plate, and transmitted to the jaw pins, pushes the grip jaws against the tapered sides of the cavity and also provides a constant retraction force on the grip jaws.

#### Control Mechanism

The control mechanism consists of a control nut and spindle. The control nut is a short steel cylinder with a center bore and internal threads. The nut threads onto the body threads. Handles on the control nut let you easily tighten and loosen the grips.

The spindle is a steel shaft with a one end either threaded or machined to accept a clevis pin, The other end is machined for a shear pin which secures a flat spindle pad. The threaded end passes through the control nut. The spindle pad slots into the base of the jaw faces. Rotation of the control nut moves the grip body while the jaw faces are held stationary. As the grip body moves, the tapers in the cavity move the grip jaws laterally to grip or release the specimen without exerting a longitudinal (tensile or compressive) force on the specimen.

#### Faces

Various jaw faces are interchangeable in each grip model size, to accommodate a range of flat or round specimen sizes. There are four jaw faces in each set; a left and right face for each upper and lower grip.

The faces are made of hardened steel and are serrated for maximum gripping effectiveness. Serrations are either 16 or 25 teeth per inch (tpi). The 16 tpi faces are preferable for use with most metals since they provide greater penetration into the specimen and longer wear. The 25 tpi faces are ideal for small diameter, thin, very hard, or penetration sensitive specimens.

## Functional

### Closed

When you turn the handles to close the grip on a specimen, the screw action of the control nut and body threads move the body away from the test specimen and push the spindle end against the jaw faces. The position of the faces remain vertically fixed, relative to the specimen, because the body is moving away from the specimen. The anti-rotation pins prevent the grip from rotating as you tighten the control nut. The angle of the jaw faces and the body wedges force the faces inward on the specimen until the face serration bite into the specimen. The gripping force increases during a test as the system applies more tensile force to the specimen.

### Open

When you turn the control handles to open the grip, the screw action of the control nut moves the body toward the test specimen. The slide plate, under tension from the spring, applies a force to the grip jaw pins to move the grip jaws away from the specimen.





# Chapter 2

## Specifications

This chapter details the grip specifications and includes a dimensional drawing of the grips.

---

- Grip Specifications ..... 17
- Jaw faces ..... 18

---

### Grip Specifications

#### Series 2716 Grips

Table 1 on page 17 details the specifications for the 2716 series of grips.

*Table 1. 2716 Series Specifications*

Cat. No.	Load Capacity/ kN (lb)	Temperature Range/C (F)	Face Width/mm (in.)	Mount <sup>1</sup>	Weight <sup>2</sup> /kg (lb)	Overall Width <sup>3</sup> /mm (in.)	Overall Length <sup>3</sup> /mm (in.)
2716-002	100 (22,500)	-73 to 250 (-100 to 480)	25.4 (1.0)	Type D <sub>M</sub>	40.0 (88.2)	144 (5.67)	254 (10.0)
2716-003	100 (22,500)	-73 to 250 (-100 to 480)	50.8 (2.0)	Type D <sub>M</sub>	60.0 (132.3)	168 (6.63)	254 (10.0)
2716-008	150 (33,700)	-73 to 250 (-100 to 480)	50.8 (2.0)	M48 x 2 Male Thread	60.0 (132.3)	178 (7.0)	340 (13.5)

1. Refer to Chapter 3- Installation for attachment interface information.
2. Weights shown are total approximate shipping weight per grip pair (less faces)
3. Dimensions shown are approximate overall width and length per grip (less control nut handles and jaw faces).

## Series 2736 Grips

Table 2 on page 18 details the specifications for the 2736 series of grips.

Table 2. 2736 Series Specifications

Cat. No.	Load Capacity/ kN (lb)	Temperature Range/C (F)	Face Width/mm (in.)	Mount <sup>1</sup>	Weight <sup>2</sup> / kg (lb)	Overall Width <sup>3</sup> / mm (in.)	Overall Length <sup>3</sup> / mm (in.)
2736-004	100 (22,500)	-73 to 315 (-100 to 600)	25.4 (1.0)	Type D <sub>M</sub>	40.0 (88.2)	144 (5.67)	254 (10.0)
2736-005	100 (22,500)	-73 to 315 (-100 to 600)	50.8 (2.0)	Type D <sub>M</sub>	60.0 (132.3)	168 (6.63)	254 (10.0)

1. Refer to Chapter 3- Installation for attachment interface information.
2. Weights shown are total approximate shipping weight per grip pair (less faces)
3. Dimensions shown are approximate overall width and length per grip (less control nut handles and jaw faces).

## Jaw faces

Jaw faces are available for testing flat or round specimens. Use flat faces for flat specimens and vee or round groove faces for round specimens. This section details the various jaw faces available.

### Caution

**Do not use serrated jaw faces to test specimens with a hardness value greater than 40 Rockwell C.**

When testing extremely hard specimens, the jaw face serrations may not adequately penetrate the specimen surface. Further, hard specimens will cause accelerated wear of the serrations.

Table 3 on page 19 lists the available jaw faces:

Table 3. Jaw face compatibility

Cat. No.	Face Type	Serrations per in.	Specimen Size/mm (in.)	Use with grips
2703-001	Flat	16	0 to 6.4 (0 to 1/4)	2716-002 or 2736-004
2703-002	Flat	16	6.3 to 12.7 (1/4 to 1/2)	2716-002 or 2736-004
2703-006	Flat	25	0 to 6.4 (0 to 1/4)	2716-002 or 2736-004
2703-007	Flat	25	6.4 to 12.7 (1/4 to 1/2)	2716-002 or 2736-004
2703-004	Vee	16	7 to 12.7 (9/32 to 1/2)	2716-002 or 2736-004
2703-008	Vee	25	3.5 to 8 (1/8 to 5/16)	2716-002 or 2736-004
2703-009	Vee	25	7 to 12.7 (9/32 to 1/2)	2716-002 or 2736-004
2703-010	Vee	25	12.7 to 19 (1/2 to 3/4)	2716-002 or 2736-004
2703-070	Round	16	12.7 to 15.8 (1/2 to 5/8)	2716-002 or 2736-004
2703-071	Round	16	15.8 to 19 (5.8 to 3/4)	2716-002 or 2736-004
2703-011	Flat	16	0 to 6.4 (0 to 1/4)	2716-003, 2716-008, or 2736-005
2703-012	Flat	16	6.4 to 12.7 (1/4 to 1/2)	2716-003, 2716-008, or 2736-005
2703-013	Vee	25	3.5 to 8 (1/8 to 5/16)	2716-003, 2716-008, or 2736-005
2703-014	Vee	25	7 to 12.7 (9/32 to 1/2)	2716-003, 2716-008, or 2736-005
2703-015	Vee	25	12.7 to 19 (1/2 to 3/4)	2716-003, 2716-008, or 2736-005
2703-072	Round	16	12.7 to 15.8 (1/2 to 5/8)	2716-003, 2716-008, or 2736-005
2703-073	Round	16	15.8 to 19 (5.8 to 3/4)	2716-003, 2716-008, or 2736-005



# Chapter 3

## Installation

This chapter contains procedures for installing the grips on a load frame, installing jaw faces and preloading the load string. Each section contains an equipment list, checklist and procedure.

---

- Attachment Methods..... 21
- Installing the Grips..... 22
- Replacing Jaw faces ..... 23

---

### Attachment Methods

The Series 2716 and 2736 wedge grips use one of two connection configurations. The 100kN models have a male shank interface. The shank is drilled to accept a clevis pin and the grip is coupled to a female clevis sleeve. The 150kN grips have a male threaded connection (M48 x 2). These grips are attached using a threaded coupling. Where the mating interfaces on the load cell or frame base or both are incompatible with the interfaces on the grips, appropriate adapters are available. In all cases, check nuts on the grips are used to remove any backlash from the interface connections and tightly secure each grip installation.

A wrench is supplied with each grip to tighten and loosen the check nuts. Two spare shear pins and two spare face guide securing screws are also supplied. Any necessary coupling adapters need to be purchased separately.

Table 4. Adapter Identification (Load Cell Interfaces)

Load Cell Interface	Adapter Required for Grip Interface	
	Male Shank (Type D)	M48 x 2 (Type II)
Clevis Type 0	2501-091 (or -093)	–
Clevis Type 1	2501-090 (or -092)	–
M30, Type I	8005-061 with 2501-356 (or 8005-061)	2501-148

Table 4. Adapter Identification (Load Cell Interfaces) (Continued)

Load Cell Interface	Adapter Required for Grip Interface	
	Male Shank (Type D)	M48 x 2 (Type II)
M48, Type II	8005-062 with 2501-356 (or 8005-062)	Direct

Table 5. Adapter Identification (Machine Base Interfaces)

Machine Base	Adapter Required for Grip Interface	
	Male Shank (Type D)	M48 x 2 (Type II)
Clevis Type D	Direct	–
Std. bolt circle, M48 x 2(F)	2501-113	Direct

## Installing the Grips

### Checklist

Check for the following conditions before you install the grips:

- There is enough clearance to install the grips between the the baseplate and the crosshead.
- All mating parts are clean and free of damage.
- You have threaded the locknuts on each grip.
- Appropriate jaw faces are installed in the grips.

### Procedures

1. Attach the grips to the load cell and the table base using any adapters required as specified in [Table 4](#) and [Table 5](#).
2. Make sure the grips are oriented and aligned correctly with easy specimen access from the front of the grip.
3. Where a clevis pin connection is used, make sure to secure the clevis pin with the correct locking clip.

4. Where a threaded connection is used, screw parts together completely and then back off as required to align and orient the grips.
5. With the grips aligned and oriented, hand-tighten the check nuts against the attachments. You may wish to install a specimen and apply a small pre-load at this stage before tightening the check nuts.

## Replacing Jaw faces

Use flat jaw faces for testing rectangular specimens and vee jaw faces for round specimens.

### Equipment

You need the following items:

- A dispenser of Molykote g-N paste.
- A set of jaw faces that are the correct size for the test sample. Refer to “[Jaw faces](#)” on page [18](#).

### Procedure

1. Rotate the control nut to the fully open position.
2. Rotate the control nut in the opposite direction to remove tension on the slide plate.
3. Loosen the side plate retaining screws.
4. Remove the side plates.
5. Remove the jaw faces.
6. Coat the back and base of the replacement jaw faces with Molykote g-N paste.
7. Place the replacement jaw faces into the grip body, with the taper facing the body wedge, and locating the face pins into the slots in the sliding plate.
8. Refit the side plates and tighten their retaining screws.





# Chapter 4

## Operation

This chapter contains procedures for installing and removing specimens. Each section contains an equipment list, a checklist and a procedure.

- 
- Installing a Specimen ..... 25
  - Removing a Specimen..... 27
- 

### Installing a Specimen

#### Warning



**Flying Object Hazard - Make sure that the specimen engages at least 2/3 of the length of the upper and lower jaw faces.**

Make sure that the specimen engages between 2/3 and the full length of the jaw faces on both the upper and lower grips, as shown in [Figure 3](#). Applying a load to a partially engaged specimen imposes loads on the grip jaws that may cause the jaw to fail resulting in possible injury and damage to other equipment.

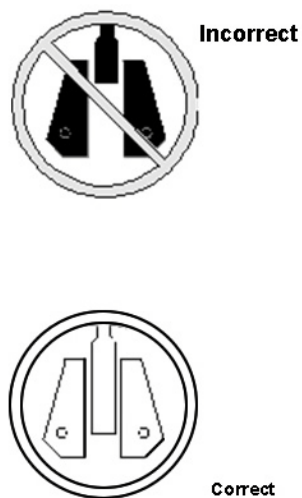

Figure 3. Correct Specimen Insertion

The force you use to turn the control nut handle determines the initial gripping pressure on the specimen. The tensile load on the specimen determines the gripping force during the test.

## Caution

---

---

**Do not exceed the maximum load rating of any load string component. Exceeding the maximum load rating of a component will damage it.**

## Caution

---

---

**Do not load the grips with compressive forces. Compressive loading removes the gripping force from the specimen.**

## Checklist

Check for the following conditions before you install a specimen:

- The grips are aligned.
- The size and type of jaw faces are appropriate for the test specimen.
- There enough space between the upper and lower grip to install the specimen.
- The load frame extension limits are set to prevent the grips from colliding.

## Procedure



*If your control system has a SPECIMEN or LOAD PROTECT function, use it when you install a specimen. Refer to the control system manual for the operational details.*

1. Separate the jaw faces by rotating the grip control nut on both grips.

## Warning

---

---



**Crush Hazard - Keep your fingers clear of the area between the jaw faces.**

## Caution

---

---

**Make sure the specimen is contacting the entire length of the jaw faces. Partial specimen engagement may damage the grips.**

1. Position the specimen in the grips so it engages the entire length of the jaw faces.

## Caution

---

**Do not over tighten the control nut. Excessive tightening can damage the grip and exert unwanted preload on the specimen.**

1. Hand-tighten the lower grip's control nut until the jaw faces engage the specimen.
2. Hand-tighten the upper grip's control nut until the jaw faces engage the specimen.

## Removing a Specimen

### Warning

---



**Do not release a specimen from the grips while the system is exerting a load on it.**

### Checklist

Check for the following conditions before you remove a specimen:

- The test system is not exerting a load on the specimen.
- There is no measuring device, such as an extensometer or LVDT, on the specimen.

### Procedure

1. Turn the upper grip control nut, according to the grip label icon, until the jaw faces no longer engage the specimen.

### Caution

---

**Secure fragile specimens by some means before you open the lower grip.**

1. Turn the lower grip control nut, according to the grip label icon, until the jaw faces no longer engage the specimen.
2. Remove the specimen.



# Chapter 5

## Maintenance

This chapter includes a maintenance checklist and a troubleshooting table to help you maintain your grips.

---

• Cleaning and Lubrication .....	29
• Shear Pin Replacement .....	30
• Troubleshooting .....	30

---

### Cleaning and Lubrication

#### Warning



Electrical Hazard - Turn the system's main power switch off before you perform any maintenance procedure.

#### Checklist

Perform the items in the following checklist after about 100 hundred cycles of opening and closing the jaw faces or more often if the system is operating in a dirty environment:

- Use a vacuum cleaner to remove specimen debris from the body cavity.
- Clean the grip body and control mechanism with a soft, lightly oiled cloth.
- Lubricate the back and bottom of the jaw faces with a thin film of Molykote g-N paste.
- Use a wire brush to remove any residual specimen material or corrosion from the jaw face serrations.
- Inspect the jaw face serrations for excessive wear. Replace any worn faces.



*Do not lubricate the gripping area of the jaw faces. Oil or grease decrease the effective gripping force and clog the grip serrations.*

## Shear Pin Replacement

Each wedge grip is equipped with a shear pin that is designed to fracture under certain test conditions in order to protect other parts from damage.

Each shear pin has a knurled head and screwdriver slot. A short section near the pin head is threaded for engagement at the front of the spindle. The remainder of the pin is unthreaded and passes through the hole in the base shaft of the spindle pad into the spindle.

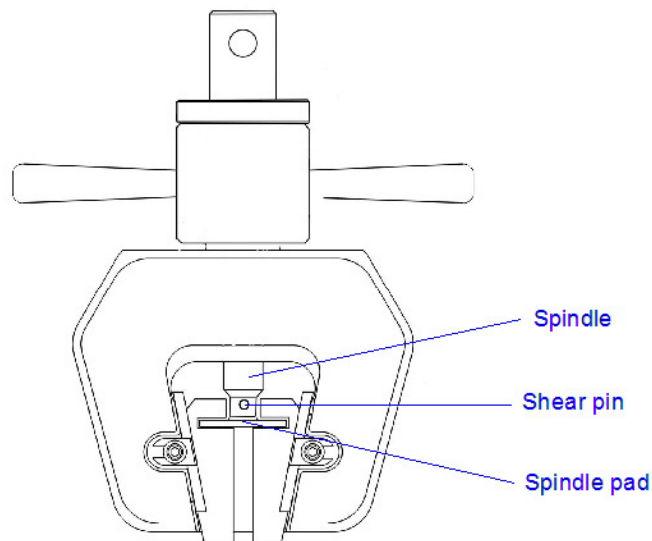

Figure 4. Shear Pin Location

To remove a sheared pin, unscrew the pin head, then carefully tap out the unthreaded fragment using a soft rod.

Align the holes on the spindle and spindle pad, then install the replacement shear pin.

## Troubleshooting

Improper adjustments or a lack of maintenance cause most grip operating problems. To help you when a problem develops, [Table 6](#) on page [31](#) suggests a probable cause and recommends a remedy. If you are unable to solve a problem contact Instron Service.



Before you contact Instron Service, note the model and serial numbers of the test system and make sure there is a telephone at the test site.

Table 6. Troubleshooting

Problem	Cause	Remedy
Specimen slips under load	Incorrect size or type of jaw face	Install the appropriate jaw face for specimen size and type
	Cyclic or compressive loads	Do not use wedge action grips for cyclic or compressive testing
	Not enough gripping area	Install specimen for complete engagement with jaw faces
	Inadequate gripping force	Tighten grip handles
	Inadequate jaw face lubrication	Lubricate rear and bottom of the jaw faces
	Load string misalignment	Verify alignment of load frame, load string components, and specimen
	Specimen surface irregularities such as scale or uneven surface	Clean and true specimen surfaces
	Specimen too hard	Do not test specimens harder than 45 Rockwell C
Specimen breaks at jaw face	Initial gripping force is too great for specimen	Do not over tighten control nut
Jaw faces do not release specimen or fail to retract	Jaw face serrations are bound to the specimen	Lightly tap specimen to release bond
	Debris or contaminants are obstructing jaw faces	Remove and clean jaw faces, clean the grip body, lubricate and reinstall jaw faces
	Tensile load on specimen	Remove load
	Inadequate jaw face lubrication	Lubricate rear and bottom of the jaw faces





# Chapter 6

## Parts

This chapter contains information on customer replaceable parts and ancillary parts for the Series 2716 and 2736 grips.

---

• Replaceable Parts .....	33
• Ancillary Parts .....	34

---

### Replaceable Parts

Refer to [Table 7](#) and [Figure 5](#) for customer replaceable parts.

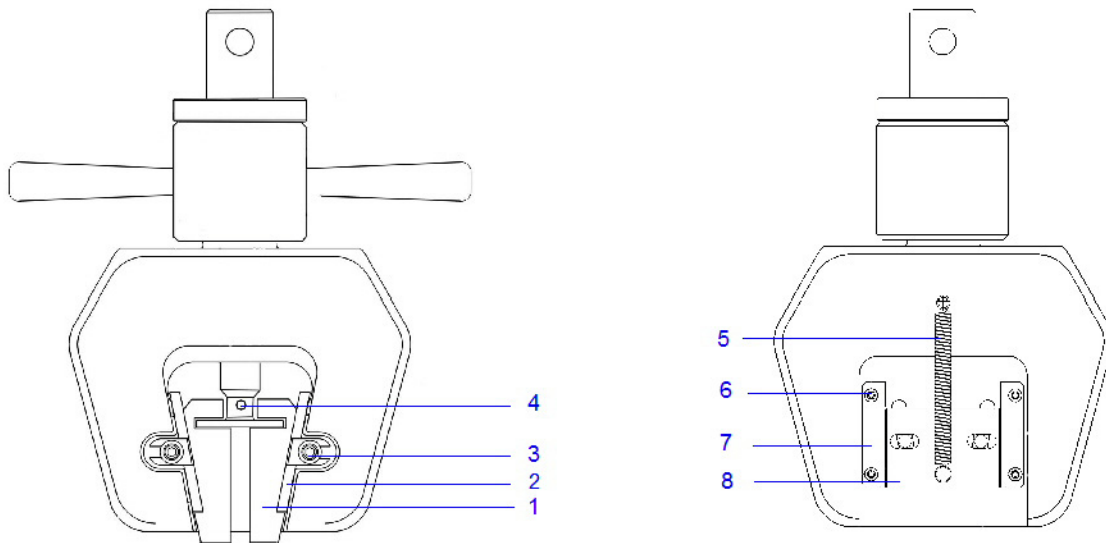

Figure 5. Replaceable Parts

Table 7. Replaceable Parts

Item	Description	Part Number	Quantity	Use with grips
1	Jaw faces	Refer to <a href="#">Table 3</a> on page <a href="#">19</a> .		
2	Guide plate	T2-307 (Left), T2-308 (Right)	1 each	All
3	Screw	T2-334	2	All
4	Shear pin	T2-304	1	All
5	Spring	66-3-6	1	All
6	Screw	201E21	4	All
7	Side retainer	T2-299	2	All
8	Slide	T2-306	1	All

## Ancillary Parts

Refer to [Table 8](#) for ancillary parts.

Table 8. Ancillary Parts

Description	Part Number
Wrench	80-4-16 (only provided with 2716-008)
Allen wrench extension	80-6-6
Molykote g-N paste	105-1-28



Product Support: [www.instron.com](http://www.instron.com)