

**Model LX Static Hydraulic  
Universal Testing System**

**Operating Instructions**  
**M47-17041-EN      Revision B**

## Electromagnetic Compatibility

Where applicable, this equipment is designed to comply with International Electromagnetic Compatibility (EMC) standards.

To ensure reproduction of this EMC performance, connect this equipment to a low impedance ground connection. Typical suitable connections are a ground spike or the steel frame of a building.

---

## Proprietary Rights Notice

This document and the information that it contains are the property of Illinois Tool Works Inc. (ITW). Rights to duplicate or otherwise copy this document and rights to disclose the document and the information that it contains to others and the right to use the information contained therein may be acquired only by written permission signed by a duly authorized officer of ITW.

---

## Trademarks

Instron® is a registered trademark of Illinois Tool Works Inc. (ITW). Other names, logos, icons and marks identifying Instron products and services referenced herein are trademarks of ITW and may not be used without the prior written permission of ITW.

Other product and company names listed are trademarks or trade names of their respective companies.

---

## Original Instructions

**Copyright © 2018 Illinois Tool Works Inc. All rights reserved. All of the specifications shown in this document are subject to change without notice.**

---

### Corporate Headquarters

Instron  
825 University Avenue  
Norwood, MA 02062-2643  
United States of America

### European Headquarters

Instron  
Coronation Road  
High Wycombe, Bucks HP12 3SY  
United Kingdom

# General Safety Precautions



Materials testing systems are potentially hazardous.

Materials testing involves inherent hazards from high forces, rapid motions, and stored energy. You must be aware of all moving and operating components in the testing system that are potentially hazardous, particularly force actuators or a moving crosshead.

Carefully read all relevant manuals and observe all Warnings and Cautions. The term Warning is used where a hazard may lead to injury or death. The term Caution is used where a hazard may lead to damage to equipment or to loss of data.

Instron products, to the best of its knowledge, comply with various national and international safety standards, in as much as they apply to materials and structural testing. We certify that our products comply with all relevant EU directives (CE mark).

Because of the wide range of applications with which our instruments are used, and over which we have no control, additional protection devices and operating procedures may be necessary due to specific accident prevention regulations, safety regulations, further EEA directives or locally valid regulations. The extent of our delivery regarding protective devices is defined in your initial sales quotation. We are thus free of liability in this respect.

At your request, we will gladly provide advice and quotations for additional safety devices such as protective shielding, warning signs or methods of restricting access to the equipment.

The following pages detail various general warnings that you must heed at all times while using materials testing equipment. You will find more specific Warnings and Cautions in the text whenever a potential hazard exists.

Your best safety precautions are to gain a thorough understanding of the equipment by reading your instruction manuals and to always use good judgment.

It is our strong recommendation that you should carry out your own product safety risk assessment.

## Warnings



### **Hazard - Press the Emergency Stop button whenever you consider that an unsafe condition exists.**

The Emergency Stop button removes hydraulic power or electrical drive from the testing system and brings the hazardous elements of the system to a stop as quickly as possible. It does not isolate the system from electrical power, other means are provided to disconnect the electrical supply. Whenever you consider that safety may be compromised, stop the test using the Emergency Stop button. Investigate and resolve the situation that caused the use of the Emergency Stop button before you reset it.



### **Flying Debris Hazard - Make sure that test specimens are installed correctly in grips or fixtures in order to eliminate stresses that can cause breakage of grip jaws or fixture components.**

Incorrect installation of test specimens creates stresses in grip jaws or fixture components that can result in breakage of these components. The high energies involved can cause the broken parts to be projected forcefully some distance from the test area. Install specimens in the center of the grip jaws in line with the load path. Insert specimens into the jaws by at least the amount recommended in your grip documentation. This amount can vary between 66% to 100% insertion depth; refer to supplied instructions for your specific grips. Use any centering and alignment devices provided.



### **Hazard - Protect electrical cables from damage and inadvertent disconnection.**

The loss of controlling and feedback signals that can result from a disconnected or damaged cable causes an open loop condition that may drive the actuator or crosshead rapidly to its extremes of motion. Protect all electrical cables, particularly transducer cables, from damage. Never route cables across the floor without protection, nor suspend cables overhead under excessive strain. Use padding to avoid chafing where cables are routed around corners or through wall openings.



### **High/Low Temperature Hazard - Wear protective clothing when handling equipment at extremes of temperature.**

Materials testing is often carried out at non-ambient temperatures using ovens, furnaces or cryogenic chambers. Extreme temperature means an operating temperature exceeding 60 °C (140 °F) or below 0 °C (32 °F). You must use protective clothing, such as gloves, when handling equipment at these temperatures. Display a warning notice concerning low or high temperature operation whenever temperature control equipment is in use. You should note that the hazard from extreme temperature can extend beyond the immediate area of the test.

## Warnings



**Crush Hazard - Take care when installing or removing a specimen, assembly, structure, or load string component.**

Installation or removal of a specimen, assembly, structure, or load string component involves working inside the hazard area between the grips or fixtures. When working in this area, ensure that other personnel cannot operate any of the system controls. Keep clear of the jaws of a grip or fixture at all times. Keep clear of the hazard area between the grips or fixtures during actuator or crosshead movement. Ensure that all actuator or crosshead movements necessary for installation or removal are slow and, where possible, at a low force setting.



**Hazard - Do not place a testing system off-line from computer control without first ensuring that no actuator or crosshead movement will occur upon transfer to manual control.**

The actuator or crosshead will immediately respond to manual control settings when the system is placed off-line from computer control. Before transferring to manual control, make sure that the control settings are such that unexpected actuator or crosshead movement cannot occur.



**Robotic Motion Hazard - Keep clear of the operating envelope of a robotic device unless the device is de-activated.**

The robot in an automated testing system presents a hazard because its movements are hard to predict. The robot can go instantly from a waiting state to high speed operation in several axes of motion. During system operation, keep away from the operating envelope of the robot. De-activate the robot before entering the envelope for any purpose, such as reloading the specimen magazine.



**Hazard - Set the appropriate limits before performing loop tuning or running waveforms or tests.**

Operational limits are included within your testing system to suspend motion or shut off the system when upper and/or lower bounds of actuator or crosshead travel, or force or strain, are reached during testing. Correct setting of operational limits by the operator, prior to testing, will reduce the risk of damage to test article and system and associated hazard to the operator.



**Electrical Hazard - Disconnect the electrical power supply before removing the covers to electrical equipment.**

Disconnect equipment from the electrical power supply before removing any electrical safety covers or replacing fuses. Do not reconnect the power source while the covers are removed. Refit covers as soon as possible.

## Warnings

---

---



**Rotating Machinery Hazard - Disconnect power supplies before removing the covers to rotating machinery.**

Disconnect equipment from all power supplies before removing any cover which gives access to rotating machinery. Do not reconnect any power supply while the covers are removed unless you are specifically instructed to do so in the manual. If the equipment needs to be operated to perform maintenance tasks with the covers removed, ensure that all loose clothing, long hair, etc. is tied back. Refit covers as soon as possible.



**Hazard - Shut down the hydraulic power supply and discharge hydraulic pressure before disconnection of any hydraulic fluid coupling.**

Do not disconnect any hydraulic coupling without first shutting down the hydraulic power supply and discharging stored pressure to zero. Tie down or otherwise secure all pressurized hoses to prevent movement during system operation and to prevent the hose from whipping about in the event of a rupture.



**Hazard - Shut off the supply of compressed gas and discharge residual gas pressure before you disconnect any compressed gas coupling.**

Do not release gas connections without first disconnecting the gas supply and discharging any residual pressure to zero.



**Explosion Hazard - Wear eye protection and use protective shields or screens whenever any possibility exists of a hazard from the failure of a specimen, assembly or structure under test.**



Wear eye protection and use protective shields or screens whenever a risk of injury to operators and observers exists from the failure of a test specimen, assembly or structure, particularly where explosive disintegration may occur. Due to the wide range of specimen materials, assemblies or structures that may be tested, any hazard resulting from the failure of a test specimen, assembly or structure is entirely the responsibility of the owner and the user of the equipment.



**Hazard - Ensure components of the load string are correctly pre-loaded to minimize the risk of fatigue failure.**

Dynamic systems, especially where load reversals through zero are occurring, are at risk of fatigue cracks developing if components of the load string are not correctly pre-loaded to one another. Apply the specified torque to all load string fasteners and the correct setting to wedge washers or spiral washers. Visually inspect highly stressed components such as grips and threaded adapters prior to every fatigue test for signs of wear or fatigue damage.

## Table of Contents

<b>Chapter 1</b>	<b>Introduction</b>	<b>9</b>
	About these instructions	9
	System overview	10
	Purpose	10
	System components	10
	Frame configuration options	11
	Testing accessories	12
	System identification	12
	Frame components	13
	System control components	15
	System safety and information labeling	16
	Product support	17
	Product documentation	17
	System verification	17
<b>Chapter 2</b>	<b>Specifications</b>	<b>19</b>
	Use limits	19
	Frame	20
	59 Series control unit	23
	Environmental conditions	24
	Heat load	24
	Noise level	24
<b>Chapter 3</b>	<b>Operation</b>	<b>27</b>
	Operation of controls	27
	Operation of HPS	31
	Isolation of HPS from the load frame	31
	Procedure for 300LX frames	31
	Procedure for 600LX frames	32
	Mount fixtures	32
	Start the system	34
	Change height of test opening	35
	Adjust the position of a J1-style crosshead	35
	Adjust the position of a J3-style crosshead	37
	Run a test	39
	Shut down the system	41
	Loss of power	42

**Chapter 4 Maintenance . . . . . 43**

- General maintenance recommendations . . . . . 43
- Preventative maintenance schedule . . . . . 43
- Make daily checks of system . . . . . 45
- Remove and install base covers . . . . . 46
- Electronics . . . . . 48
  - Clean the fans . . . . . 48
  - Fuses . . . . . 48
  - Inspect the cables . . . . . 48
- Frame . . . . . 48
  - Inspect the hydraulic cylinder . . . . . 48
  - Crosshead . . . . . 49
  - Clean the columns . . . . . 50
- Hydraulic power supply (HPS) . . . . . 50
  - Check the oil cleanliness . . . . . 50
  - Add oil to reservoir . . . . . 50
  - Change the oil . . . . . 53
  - Change the air breather filter . . . . . 55
  - Inspect the hydraulic hoses . . . . . 55
  - Replace the hydraulic hoses . . . . . 55
  - Oil type and quantity . . . . . 56
- Ancillary parts . . . . . 57
- Consumable parts . . . . . 58
- Spare and replacement parts . . . . . 58

**Appendix A CE Certificate . . . . . 59**



# Chapter 1

## Introduction

---

• About these instructions . . . . .	9
• System overview . . . . .	10
• Frame components . . . . .	13
• System control components . . . . .	15
• System safety and information labeling . . . . .	16
• Product support . . . . .	17
• Product documentation . . . . .	17
• System verification . . . . .	17

---

### About these instructions

These instructions describe the function, operation and maintenance for various models of the LX testing systems. If unsure of your specific model, refer to “[System identification](#)” on page [12](#).

These instructions assume the following:

- You are an operator familiar with the operation of materials testing systems in general.
- Your system has been installed in its final location according to the requirements outlined in the system’s Pre-Installation Manual.
- Your system consists of a frame, a hydraulic power supply, a control unit, a computer system with an Instron materials testing software package, and any testing accessories necessary to secure the specimen in the test space.
- Software test methods that are appropriate for your testing requirements are available.

These instructions do not include the development of test methods within the materials testing software. This is covered in more advanced training that can be provided by Instron Service and Training departments.

Throughout your documentation are NOTE, CAUTION and WARNING statements that alert you to important information. They appear as follows:



*Notes provide further clarification on particular issues.*

---

### Caution

**Cautions alert the user to situations that may cause equipment damage.**

---

### Warning



**Warnings alert the user to situations that may cause serious personal injury or death.**

---

Please read these instructions, and any other documents provided, thoroughly and carefully. Be sure to understand all Warnings and Cautions before attempting to operate any of the system in whole or in part.

## System overview

### Purpose

#### Warning

---



**If the equipment is used in a manner not specified by Instron, the protection provided by the equipment may be impaired. Injury to personnel or damage to the system may result. Be sure to read and understand the material presented in these instructions and in any other accompanying instructions.**

---

The Instron Model LX Static Hydraulic Universal Testing Systems are available in a variety of capacities. They are ideally suited for tensile proof and ultimate strength tests on specimens such as fasteners, chain, threaded end, shoulder end, wire, rod and sheet materials. With appropriate fixtures, they can also be used for compression, bend and shear testing. These frames feature a single, large test space and long test stroke that, together, provide users with great flexibility in the specimen size that can be tested and in the grips, fixtures and extensometry that can be used for the test.

## System components

Model LX systems consist of:

- Frame
- Hydraulic Power Supply (HPS)
- 59 Series control unit and other system controls and electronics
- Instron approved computer system with Instron materials testing software

[Figure 1](#) identifies the system components and various frame configurations (see “[Frame configuration options](#)” on page [11](#)).

1. J1-style crosshead - Crosshead adjustable to fixed positions, adjusted and secured manually
2. J3-style crosshead - Crosshead infinitely adjustable throughout its range, adjusted and secured with hydraulic crosshead lift and lock cylinders
3. HPS and electronics located in base of frame

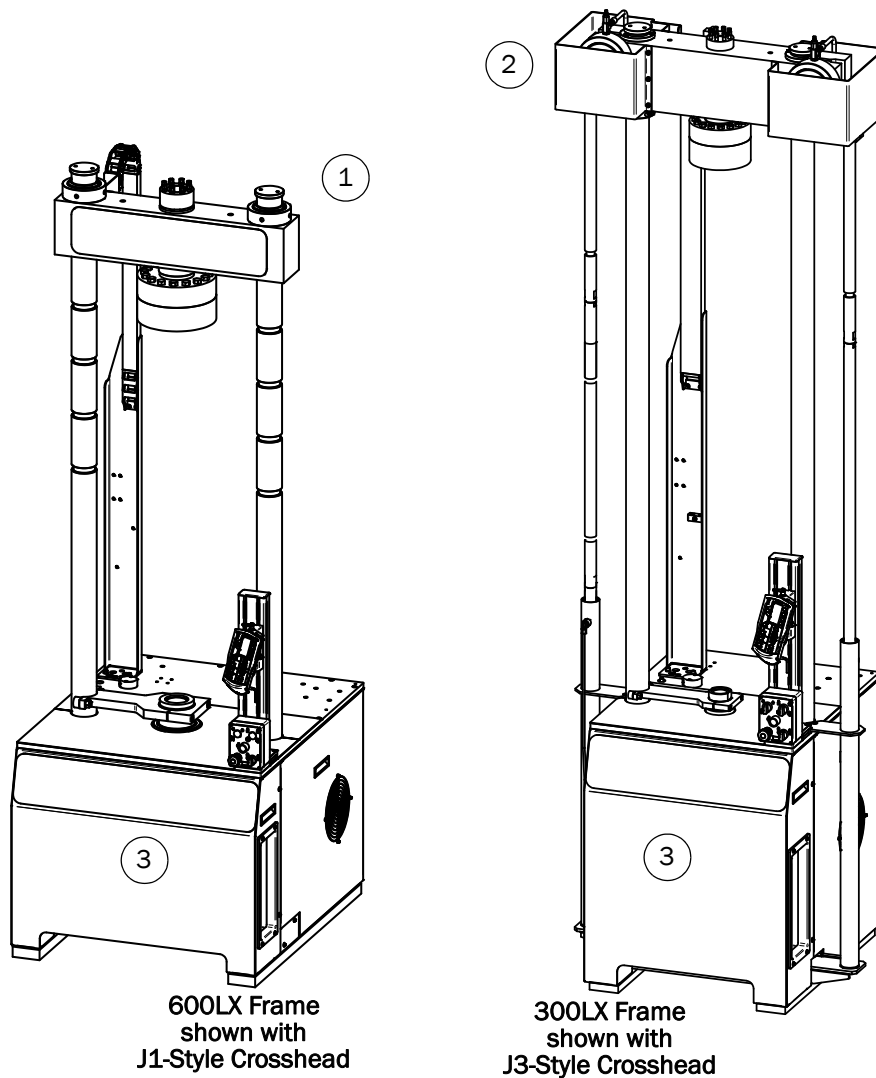

Figure 1. LX testing systems - various configurations shown.

## Frame configuration options

Frames can be configured with a variety of options. These options include:

- Crosshead variations:
  - J1-style crosshead - Crosshead adjustable to fixed positions, adjusted and secured manually

- J3-style crosshead - Crosshead infinitely adjustable throughout its range, adjusted and secured with hydraulic crosshead lift and lock cylinders
- Test opening variations:
  - E1 - Standard tension opening
  - E2 - Increase tension test space by: 610 mm (24 in) for 300DX frames, 406.4 mm (16 in) for 600DX frames
  - E3 - Increase tension test space by 915 mm (36 in)

The configuration options selected for your frame are identified in the complete model number of the frame. The complete model number is defined as:

{Capacity (in kN)}{Model family}-{Controller}{Crosshead style option}{Test opening option}

Some examples would be:

300LX-V1-J1-E1, 300LX-V1-J3-E3, 600LX-V1-J1-E1, 600LX-V1-J3-E3

It is very important to be aware of and understand the configuration of your frame as you perform various operations and procedures so that they can be performed correctly - the complete model number (in whole or in part) is used throughout this manual to identify specifications and procedures appropriate for your frame configuration. Knowing the complete model number of your frame is critical. To determine the complete model number (and thus configuration) of your frame, refer to one of the following:

- The frame serial tag (see “[System identification](#)” on page 12)
- The Instron quote

## Testing accessories

Testing accessories are purchased separately from the frame. Testing accessories either provide a means to secure the specimen in the test space or provide additional functionality to the frame. Instructions on the installation, use and maintenance of Instron testing accessories are provided separately with each testing accessory. A variety of testing accessories are available. Contact your Instron Sales Representative for more information.

## System identification

Your system has been given a unique serial number for system identification. This serial number can be found on the serial tag located on the rear of the frame (i.e. the frame serial tag).

The frame serial tag includes other important system information, including information on your frame's configuration. Frame configuration information can also be found on your Instron quote. Refer to “[Frame configuration options](#)” on page 11 for explanation of frame configuration.

## Frame components

Refer to [Figure 2](#) and [Table 1](#) to identify components of the frame. For proper operation of the system, it is important to be able to identify and to understand the basic function of these components.

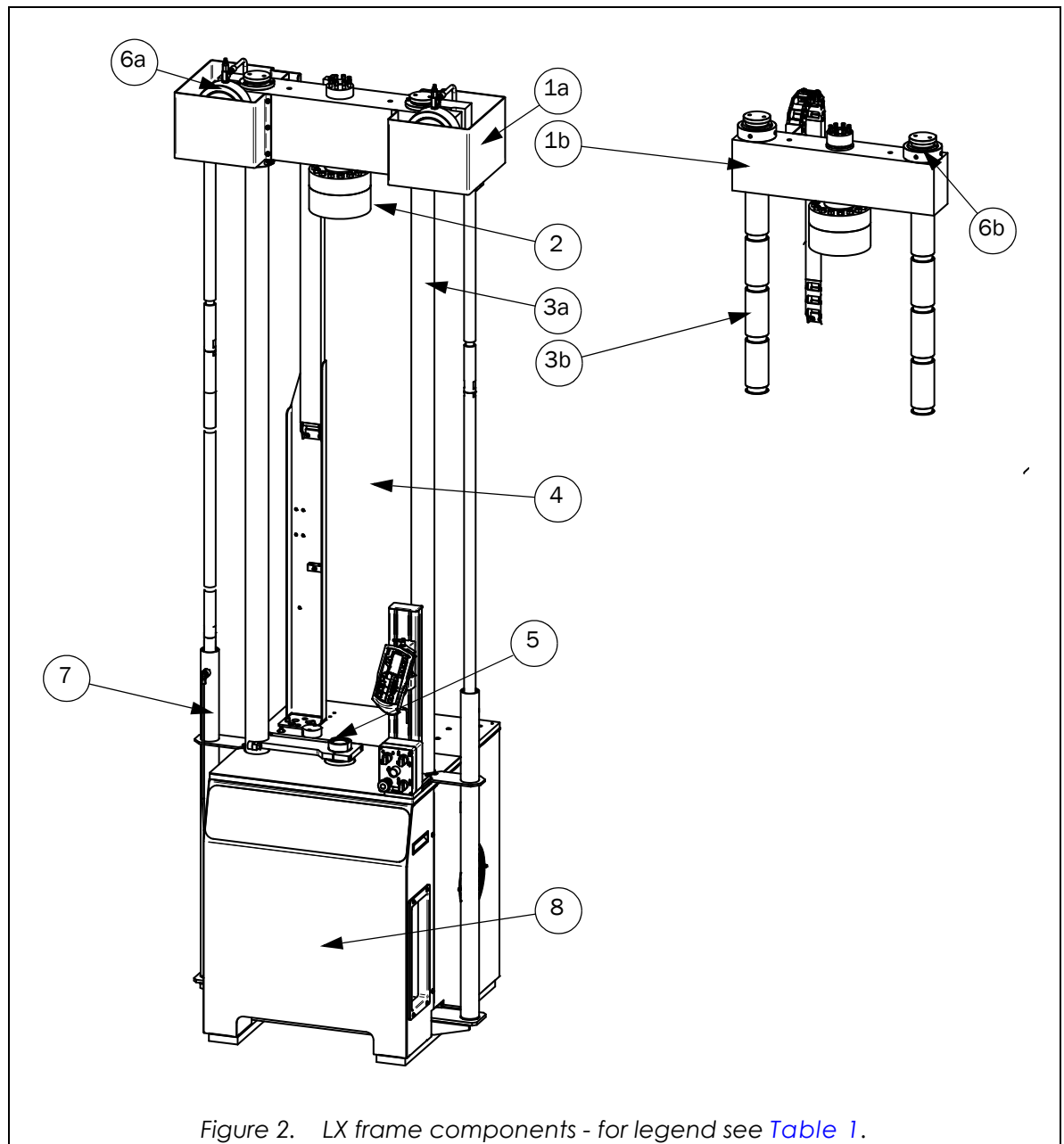





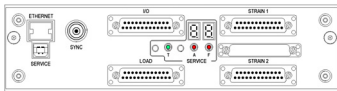

Table 1. Frame component descriptions, see [Figure 2](#).

Component	Description
1. Crosshead a. J3-style b. J1-style	Provides mounting for load cell. Position of crosshead can be adjusted to change the vertical opening of the test space. Refer to <a href="#">“Change height of test opening”</a> on page 35 for more information.
2. Load cell	Measures the force applied to the specimen. One end of the specimen is mounted to the load cell using appropriate specimen fixtures (purchased separately).
3. Columns a. J3-style b. J1-style	Connect the crosshead to the base. Columns for J1-style crosshead are notched. Columns for J3-style crosshead are smooth.
4. Test space	Area where tests are performed. The vertical opening of the test space can be adjusted. Refer to <a href="#">“Change height of test opening”</a> on page 35 for more information.
5. Hydraulic cylinder	Applies load to the specimen during the test. One end of the specimen is mounted to the hydraulic cylinder using appropriate specimen fixtures (purchased separately).
6. Crosshead lock mechanisms a. J3-style b. J1-style	Lock the crosshead to the columns. Operated either manually (J1-style crossheads) or hydraulically (J3-style crossheads). Refer to <a href="#">“Change height of test opening”</a> on page 35 for more information. <b>Provided on J1-style and J3-style crossheads only.</b>
7. Crosshead lift cylinders	Provide hydraulic adjustment of the crosshead on the columns. Refer to <a href="#">“Adjust the position of a J3-style crosshead”</a> on page 37 for more information. <b>Provided on J3-style crossheads only.</b>
8. Base	Provides mounting for hydraulic cylinder. Houses the hydraulic power supply (HPS).

## System control components

Refer to [Table 2](#) to identify control components of the system. For proper operation of the system, it is important to be able to identify and to understand the basic function of these components.



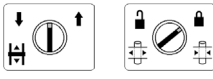







Table 2. System control descriptions.

Component	Description
Emergency stop	 <p>Press this button to immediately stop motion of the frame. This stops all frame motion and disables the frame. This button will take precedence over all other system controls. Refer to <a href="#">Table 9</a> on page 25 for more information.</p>
Main power disconnect switch	 <p>Provides control of main power to the system. When the switch is off, all power to the frame, HPS and all system controls are shut off. Power to the computer system is unaffected as it has its own power supply.</p>
Pump start	 <p>Press this button to start the HPS. Refer to <a href="#">Table 9</a> on page 25 for more information.</p>
59 Series control unit	 <p>The 59 Series control unit houses control components that: receive and process data from the various system transducers; communicate with the system's controlling software; and provide feedback to the system's servo valve to operate the frame as set up in the controlling software. Refer to <a href="#">Table 9</a> on page 25 for more information.</p>
User control panel	 <p>The controls on this panel allow the operator to manually adjust the hydraulic cylinder, to start and stop tests, to reset and return to the zero extension point and other testing controls/functions. Refer to <a href="#">Table 9</a> on page 25 for more information.</p>
Tension/compression control switch	 <p>Allows the operator to place hydraulic demand at the appropriate side of the hydraulic cylinder for testing in the direction required (tension or compression).</p>
Crosshead lift and lock controls	 <p>Allows the operator to control the hydraulic lift and lock cylinders for adjustment of the crosshead. Adjustment of the crosshead changes the height of the test opening. <b>Supplied with J3-style crossheads only.</b></p>

# System safety and information labeling

Table 3 explains the meanings of any safety and information labels that may be attached to any part of the testing system.

Table 3. Descriptions of safety and information labeling.

Label	Meaning and Purpose
	<p><b>Crush hazard</b> - Indicates that a pinching or crush hazard exists from two objects coming together and instructs the user to read and understand the operator’s manual before using the machine.</p>
	<p><b>Electrical hazard</b> - Indicates that a hazard exists from high voltage or electrical current.</p>
	<p><b>Electrical hazard</b> - Indicates that a hazard exists from leakage current and that the equipment must be connected to a mains ground point.</p>
	<p><b>High pressure hazard</b> - Indicates that a hazard exists from high pressure. Do not adjust or reset any pressure settings until you have read and understood the operator’s manual. Personal injury or damage to equipment may result. Most pressure settings should only be adjusted by an Instron service engineer.</p>
	<p><b>Eye protection</b> - Indicates that a flying debris hazard exists either from specimen failure or improper use of system components. Wear eye protection or use protective shields or screens. Be sure to read and understand the operator’s manual before using the system.</p>
	<p><b>Read the manual</b> - Read and understand the operator’s manual before using the system.</p>
	<p><b>Guard removal hazard</b> - Indicates that a hazard exists - do not operate the system with covers removed. Be sure to read and understand the operator’s manual before using the system. Only authorized personnel should service the equipment.</p>
	<p><b>Ground stud</b> - Indicates a ground stud. Connect to an appropriate ground/earth system.</p>
	<p><b>Protective earth</b> - Indicates the protective earth terminal for the main power supply.</p>
	<p><b>Three-phase power supply</b> - Indicates that the equipment requires a three-phase power supply.</p>



## Product support

Instron provides documentation, including manuals and online help, that can answer many of the questions you may have. It is recommended that you review the documentation sent with the system you purchased for possible solutions to your questions.

If you cannot find answers in these sources, contact Instron's Services department directly. A list of Instron offices is available on our website at [www.instron.com](http://www.instron.com). You may email your questions to [service\\_support@instron.com](mailto:service_support@instron.com) (if your system is still in warranty, please include "IPG Warranty" in the subject line). In the US and Canada, you can call directly at 1-800-473-7838.

## Product documentation

Instron offers a comprehensive range of documentation to help you get the most out of your Instron products. Depending on what you have purchased, your documentation may include some or all of the following:

Pre-Installation Manual	Information about preparing your site for installation of the system, receiving the system, and lifting and handling of the system.
Operating Instructions	How to use your system components and controls, and other frequently performed operating tasks.
System Concepts	Additional information about your system.
Online Help	Software products come complete with context sensitive help, which provides detailed information on how to use all software features.
Accessory Equipment Reference	How to set up and use any accessories you have purchased, for example grips, fixtures, extensometers, transducers, hydraulic power units, non-standard actuators, and environmental chambers.

We welcome your feedback on any aspect of the product documentation. Please email [info\\_dev@instron.com](mailto:info_dev@instron.com) with your comments.

## System verification

### Caution

**System verification is vital to ensure the accuracy of your calibration. Current standards recommend that you do not exceed 18 months between verifications.**

Instron provides a fully traceable verification service including UKAS/NVLAP certification where appropriate. Contact your local Instron Representative for details.



# Chapter 2

## Specifications

- Use limits . . . . . 19
- Frame . . . . . 20
- 59 Series control unit . . . . . 23
- Environmental conditions . . . . . 24
- Heat load . . . . . 24
- Noise level . . . . . 24

### Use limits

Table 4 gives information on the use limits of the testing system, as determined in accordance with ISO 12100, section 5.3.2.

Table 4. Use limits of the testing system.

<b>Intended use and foreseeable misuse:</b>	<p>When fit with appropriate fixtures, the system is intended to conduct static tension, compression, bend, flexure and shear tests on a variety of specimen shapes and material types. The material types must be limited to those that break into no more than two pieces that will be retained in the fixtures or whose failure does not result in hazardous projectiles. The system can operate in servo control mode only through an Instron Materials Testing Software package. The system must never be left unattended while in operation.</p> <p>The system should not be used for any purpose other than static testing of the material types specified above. It must not be used to test specimens of material types that result in hazardous projectiles unless an interlocked guard with an appropriate performance level is added. You must conduct your own risk assessment and take appropriate measures to prevent operator injury and guard the equipment. Instron offers safety rated guards for this purpose. Please contact your local Instron representative for more information.</p> <p>The system must not be used as a press. The system should not be operated by anyone who does not fit the criteria specified in the “<b>Operator characteristics:</b>” and “<b>Operator training/experience:</b>” sections of this table.</p>
<b>Intervention procedures:</b>	The system is equipped with <b>Emergency Stop</b> and software reset (frame enable) controls (see Table 2 on page 15 and separately supplied Software documentation).
<b>Use type:</b>	Industrial
<b>Operator characteristics:</b>	Typical adult in good health with no disabilities that prevent safe operation of the testing system.
<b>Operator training/experience:</b>	<p><b>Operators</b> should be familiar with the operation of materials testing systems in general and with the inherent hazards of such testing in particular. Operators should gain a thorough understanding of this equipment by reading these instructions and all other documents provided. Initial basic safety and operational training is provided by Instron Service personnel during installation of the system.</p> <p><b>Maintenance personnel or technicians</b> should have sufficient training and skills so that they can safely perform all procedures outlined in Chapter 4 beginning on page 43.</p> <p><b>Trainees and apprentices</b> should only operate or maintain the system under direct supervision of a qualified operator or maintenance personnel.</p> <p><b>The general public</b> should not have access to the system.</p>
<b>Exposure of other persons to hazards:</b>	Exposure to hazards is greatly reduced by the knowledge of qualified operators. Anyone who does not fit the criteria specified in the “ <b>Operator characteristics:</b> ” and “ <b>Operator training/experience:</b> ” sections of this table should not have access to the system.

## Frame

The technical specifications for the various standard LX frames can be found in [Table 5](#). If unsure of the options included with your frame, check the model number listed on the frame's serial number tag; it includes option designations.

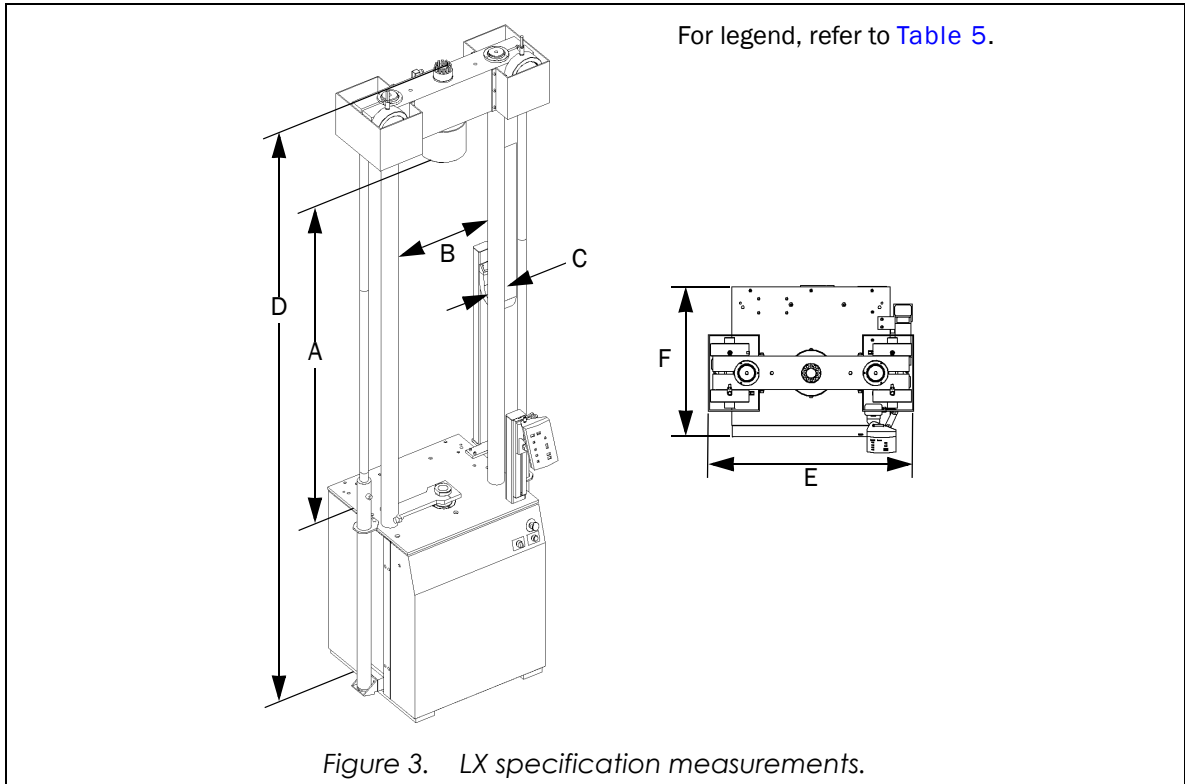

Table 5. LX frame technical specifications.

Specification <sup>1</sup>		300LX	600LX
Maximum Capacity <sup>2</sup>		300 kN 30,000 kgf 67,500 lbf	600 kN 60,000 kgf 135,000 lbf
Design Capacity <sup>3</sup>		240 kN 24,000 kgf 54,000 lbf	480 kN 48,000 kgf 108,000 lbf
<b>(A) Test Opening</b> (per crosshead style and crosshead position) <sup>4</sup>			
J1-E1 H1	First notch	305 - 610 mm (12 - 24 in)	305 - 610 mm (12 - 24 in)
	Second notch	483 - 787 mm (19 - 31 in)	508 - 813 mm (20 - 32 in)
	Third notch	660 - 965 mm (26 - 38 in)	711 - 1016 mm (28 - 40 in)
J1-E1 H2	First notch	127 - 432 mm (5 - 17 in)	102 - 406 mm (4 - 16 in)
	Second notch	305 - 610 mm (12 - 24 in)	305 - 610 mm (12 - 24 in)
	Third notch	483 - 787 mm (19 - 31 in)	508 - 813 mm (20 - 32 in)

Table 5. LX frame technical specifications. (Continued)

Specification <sup>1</sup>		300LX	600LX
J1-E2 H1	First notch	305 - 610 mm (12 - 24 in)	305 - 610 mm (12 - 24 in)
	Second notch	483 - 787 mm (19 - 31 in)	508 - 813 mm (20 - 32 in)
	Third notch	660 - 965 mm (26 - 38 in)	711 - 1016 mm (28 - 40 in)
	Fourth notch	838 - 1143 mm (33 - 45 in)	914 - 1219 mm (36 - 48 in)
	Fifth notch	1016 - 1321 mm (40 - 52 in)	1118 - 1422 mm (44 - 56 in)
J1-E2 H2	First notch	127 - 432 mm (5 - 17 in)	102 - 406 mm (4 - 16 in)
	Second notch	305 - 610 mm (12 - 24 in)	305 - 610 mm (12 - 24 in)
	Third notch	483 - 787 mm (19 - 31 in)	508 - 813 mm (20 - 32 in)
	Fourth notch	660 - 965 mm (26 - 38 in)	711 - 1016 mm (28 - 40 in)
	Fifth notch	838 - 1143 mm (33 - 45 in)	914 - 1219 mm (36 - 48 in)
J1-E3 H1	First notch	305 - 610 mm (12 - 24 in)	305 - 610 mm (12 - 24 in)
	Second notch	483 - 787 mm (19 - 31 in)	508 - 813 mm (20 - 32 in)
	Third notch	660 - 965 mm (26 - 38 in)	711 - 1016 mm (28 - 40 in)
	Fourth notch	838 - 1143 mm (33 - 45 in)	914 - 1219 mm (36 - 48 in)
	Fifth notch	1016 - 1321 mm (40 - 52 in)	1118 - 1422 mm (44 - 56 in)
	Sixth notch	1194 - 1499 mm (47 - 59 in)	1321 - 1626 mm (52 - 64 in)
	Seventh notch	1372 - 1676 mm (54 - 66 in)	1524 - 1829 mm (60 - 72 in)
	Eighth notch	1549 - 1854 mm (61 - 73 in)	1727 - 2032 mm (68 - 80 in)
J1-E3 H2	First notch	127 - 432 mm (5 - 17 in)	102 - 406 mm (4 - 16 in)
	Second notch	305 - 610 mm (12 - 24 in)	305 - 610 mm (12 - 24 in)
	Third notch	483 - 787 mm (19 - 31 in)	508 - 813 mm (20 - 32 in)
	Fourth notch	660 - 965 mm (26 - 38 in)	711 - 1016 mm (28 - 40 in)
	Fifth notch	838 - 1143 mm (33 - 45 in)	914 - 1219 mm (36 - 48 in)
	Sixth notch	1016 - 1321 mm (40 - 52 in)	1118 - 1422 mm (44 - 56 in)
	Seventh notch	1194 - 1499 mm (47 - 59 in)	1321 - 1626 mm (52 - 64 in)
	Eighth notch	1372 - 1676 mm (54 - 66 in)	1524 - 1828 mm (60 - 72 in)
J3-E3 H1	Lower	0 - 1295 mm (0 - 51 in)	0 - 1295 mm (0 - 51 in)
	Upper	559 - 1854 mm (22 - 73 in)	737 - 2032 mm (29 - 80 in)
J3-E3 H2	Lower	0 - 1118 mm (0 - 44 in)	0 - 1118 mm (0 - 44 in)
	Upper	381 - 1676 mm (15 - 66 in)	553 - 1829 mm (21 - 72 in)
<b>(B) Horizontal Test Width</b>		508 mm (20 in)	609 mm (24 in)
<b>Horizontal Test Depth</b>		Depth is only limited by the fixture being mounted to the hydraulic cylinder. Compression fixtures may need additional support to achieve full capacity. Tension fixtures typically do not have any support limitations. Consult Instron Sales for specific application questions.	

Table 5. LX frame technical specifications. (Continued)

Specification <sup>1</sup>	300LX	600LX
<b>Stroke</b>	305 mm (12 in)	305 mm (12 in)
<b>(C) Column Diameter</b>	76 mm (3 in)	89 mm (3.5 in)
<b>(D) Maximum Overall Height</b>	Refer to the appropriate General Assembly drawing provided in the "Reference Manual-Equipment" <sup>5</sup>	
<b>Overall Frame Area (width (E) x depth (F))</b>		
J1	743 x 994 mm (29 x 39.125 in)	920 x 1207 mm (36.25 x 47.5 in)
J3	1039 x 994 mm (40.875 x 39.125 in)	1250 x 1207 mm (49.25 x 47.5 in)
<b>Weight</b>	Refer to the appropriate General Assembly drawing provided in the "Reference Manual-Equipment" <sup>5</sup>	
<b>Speed Information</b>		
<b>Testing Speed Range</b> (at full load)	0.1 to 150 mm/min (0.004 to 6 in/min)	0.1 to 76 mm/min (0.004 to 3 in/min)
<b>Jog (Adjusting) Speed</b> (Maximum)	150 mm/min (6 in/min)	76 mm/min (3 in/min)
<b>Position Information</b>		
<b>Accuracy<sup>6</sup></b>		
C4	Equal to or less than +/-0.13 mm (0.005 in) or +/-0.1% of displayed reading, whichever is greater	
<b>Resolution<sup>7</sup></b>		
C4	1 µm (0.00004 in)	
<b>Cyclic Test and Frequency Limits</b>	Capable of tension/tension or compression/compression cyclic testing only. Cyclic tests are limited to ramp type waveforms as defined within the materials testing software package being used with the system. Frequency limits are defined by the compliance of the specimen and the dynamic control limit of the system. For cyclic tests based on a load rate, the load rate should not exceed a rate equivalent to the capacity of the frame in a 30 second period. Some variation in this loading rate will be experienced based on specimen compliance. Although this may be used as a guideline, further limitations will be encountered if the loading rate creates a speed requirement near the maximum speed of the hydraulic cylinder. In all cases, the frequency for cyclic testing is limited to 1 Hz or less.	
<b>Center Alignment<sup>8</sup> (estimated)</b>	Estimated axial alignment between the actuator rod and central thread in the load cell with crosshead in lowest position is 0.64 mm (0.025 in)	
<b>Power Requirements</b>	200-250 VAC, 3Phase, 50/60 Hz, 15 Amp 380-415 VAC, 3Phase, 50/60 Hz, 10 Amp 440-480 VAC, 3Phase, 50/60 Hz, 10 Amp	
<b>Certifications</b>	Conform to all relevant European standards and carry a CE mark	

1. J1 = Manually adjustable crosshead with manual crosshead locks  
 J3 = Hydraulically adjustable crosshead with hydraulic crosshead locks  
 H1 = Anti-rotation only, no guidance  
 H2 = Heavy-duty guidance  
 E1 = Standard tension opening  
 E2 = Extended tension opening by:
  - 356 mm (14 in) for 300LX frames
  - 406.4 mm (16 in) for 600LX frames
 E3 = Extended tension opening by:
  - 889 mm (35 in) for 300LX frames
  - 1016 mm (40 in) for 600LX frames
2. Long term static tests should be limited to 30 minutes or less when the test is performed at or near maximum capacity. Time varies inversely with test load. 50% maximum capacity tests should be limited to 60 minutes or less. An oil temperature switch limits test duration based on safe reservoir temperature. Assumes ambient temperature of 25 deg C (77 deg F).
3. The design capacity is the peak load at which the frame should be used for no more than 80% of the time. In other words, at least 80% of specimen testing should be conducted at peak loads that are at or below the design capacity. The frame should only be used at loads between the design capacity and the maximum capacity less than 20% of the time.
4. For J1-style crossheads, the minimum and maximum test opening is provided for each notch position of the crosshead. First notch position is with the crosshead in the lowest notch on the columns. Number of notch positions provided depends on frame height option purchased; not all frames have all notch positions listed. Minimum opening is with the hydraulic cylinder fully extended. Maximum opening is with the hydraulic cylinder fully retracted. Values do not include specimen fixtures.
5. The General Assembly drawing is located in the separately supplied "Reference Manual-Equipment". General Assembly drawings are model specific; please be sure to refer to the appropriate drawing for your model and its configuration.
6. Under no load conditions. Accuracy is affected under load. The encoder cannot compensate for frame deflection (axial stiffness) or the load cell and load string deflections. Over short travels and higher loads, the error could be over 100%. Conversely, over longer travels and lower loads, the error may be insignificant. The axial frame stiffness and load cell stiffness values published may be used to assess this affect. The load string also needs to be considered. In general, the extension (position) readout should not be used as the primary strain measuring device where an extensometer on the specimen is clearly warranted. Frame compliance can be accounted for to some extent by Instron software.
7. At speeds below approximately 0.1 mm/min (0.004 in/min) the hydraulic cylinder moves in increments approximately equal to these values and can be seen as load steps depending on the specimen stiffness and load range.
8. Center alignment is a theoretical value based on the tolerance accumulation of machined components. Use of grips and fixtures will affect this estimate. In applications requiring precision alignment, an alignment device is recommended.

## 59 Series control unit

Table 6. 59 Series control unit technical specifications.

<b>Data Sampling</b>	40 kHz
<b>Data Capture</b>	Selectable up to 1000 Hz <sup>1</sup> Intelligent data capture Synchronous on all channels
<b>Digital Signal Processor</b>	32-bit floating point Self-test diagnostics Real-time closed-loop control Real-time data acquisition
<b>Data Transfer to Computer</b>	1000 Hz
<b>Transducer Inputs</b>	Standard Instron rationalized transducers Any 0-10 V analog DC input
<b>Transducer Resolution</b>	1 part in 500,000 of +/- full scale (19 bits)
<b>Load Measurement Accuracy</b>	+/- 0.5% of reading down to 1/500 of load cell capacity
<b>Linearity</b>	+/- 0.25% of reading over a range of 0.2% to 100% of capacity

Table 6. 59 Series control unit technical specifications.

<b>Repeatability</b>	+/- 0.25% of reading over a range of 0.2% to 100% of capacity
<b>Strain Measurement Accuracy</b>	+/- 0.5% of reading down to 1/50 of full range with ASTM E 83 class B-1 or B-2, or ISO 9513 class 0.5 extensometer
<b>Certifications</b>	Conform to all relevant European standards

1. Software data capture rate may vary.

## Environmental conditions

Table 7 lists the recommended environmental conditions in which the system should be operated and stored.

Table 7. Recommended environmental conditions.

<b>Operating Temperature:</b>	+10 to +38 deg C (+50 to +100 deg F)
<b>Storage Temperature:</b>	-40 to +66 deg C (-40 to +150 deg F)
<b>Humidity:</b>	10% to 90% (non-condensing)
<b>Atmosphere:</b>	Designed for use under normal laboratory conditions. Protective measures may be required if excessive dust, corrosive fumes, electromagnetic fields, or hazardous conditions are encountered.

## Heat load

The HPS generates a certain amount of heat during operation. Refer to Table 8 for the approximate heat output of the HPS operating at both a 10% duty cycle and 50% duty cycle. The duty cycle is defined as the amount of time that the HPS operates under full load conditions. For example, operating at a 10% duty cycle would mean performing approximately one 6-minute test at full load per hour.

Table 8. Approximate heat output of various frame models.

Frame Model	Approximate Heat Output at 10% Duty Cycle	Approximate Heat Output at 50% Duty Cycle
300LX	230 W (787 BTU/hour)	452 W (1544 BTU/hour)
600LX	233 W (797 BTU/hour)	467 W (1594 BTU/hour)

## Noise level

The A-weighted emission sound pressure level generated by the testing system under normal operating conditions does not exceed 70 dBA. The peak C-weighted instantaneous sound pressure value does not exceed 63 Pa.

Since many variables (such as room layout) affect noise levels, it can not be assumed that these readings will be equal to those in the field. The noise level readings were taken at a location in front of the system as shown in Figure 4. This is the typical location for an operator to stand when operating the system.



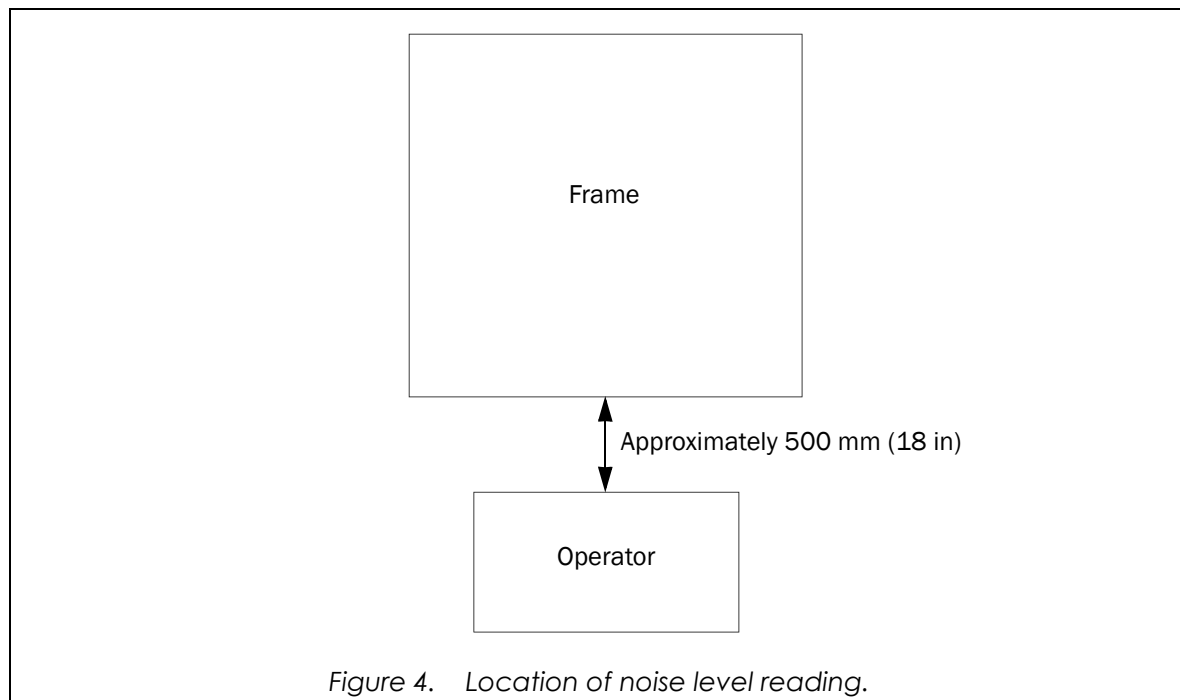

Figure 4. Location of noise level reading.



# Chapter 3

## Operation

- Operation of controls ..... 27
- Operation of HPS..... 31
- Mount fixtures..... 32
- Start the system ..... 34
- Change height of test opening..... 35
- Run a test ..... 39
- Shut down the system ..... 41
- Loss of power ..... 42

### Warning



Always wear appropriate personal protective equipment when preparing, operating and maintaining this equipment. Personal protective equipment should include, but is not limited to, eye protection and head protection. Other types of personal protective equipment may also be needed. You must perform your own risk assessment and take appropriate measures to protect yourself from harm.

## Operation of controls

Table 9 provides details on the function and operation of various system controls. The controls supplied with the system depend on options purchased - not all controls listed in Table 9 are supplied with every system.

Table 9. Control functions.

Control	Location	Description
<b>Emergency stop</b> 	HPS control box	When it is necessary to stop motion of the frame immediately, press the <b>Emergency Stop</b> button. This shuts down the HPS and disables the frame. To resume operation: <ol style="list-style-type: none"> <li>1. Release the <b>Emergency Stop</b> button by turning it clockwise as depicted by the arrows on the knob face.</li> <li>2. Enable the frame in the controlling software.</li> <li>3. Press the <b>Pump Start</b> button. The green indicator light should illuminate and the HPS should start.</li> </ol>
<b>Pump start</b> 	HPS control box	Turns on the HPS. The frame must be enabled through the controlling software before the HPS can be started. The button will illuminate when the HPS is on.

Table 9. Control functions. (Continued)

Control	Location	Description
<b>Tension/compression control switch</b> 	HPS control box	Set the switch to the desired testing direction before starting a test. If the switch is not set to the correct direction for the test, the frame will not respond as directed by the controls. This will cause a position loop or sensor loop error to occur and the controller will turn off the HPS. The controlling software will indicate the type of error that occurred. The switch should not be changed once a test is started.
<b>Crosshead lift and lock controls</b> 	HPS control box	Detailed operation of these controls is provided in “ <a href="#">Adjust the position of a J3-style crosshead</a> ” on page 37. Read this information before operating these controls. <b>Supplied with J3-style crossheads only.</b>
<b>Display and associated buttons</b>	User control panel ( <a href="#">Figure 5</a> )	<p>The display and its associated buttons operate together with the controlling software. The numbered buttons, labeled <b>1</b>, <b>2</b>, <b>3</b> and <b>4</b>, operate as either “soft keys” or “live display keys” and the button to the left of the display is the toggle button that switches the numbered buttons between those two operations.</p> <p>As soft keys, you can assign up to four functions that you use frequently, such as Balance Load. Any soft key functions that you have assigned in the controlling software are shown in the display next to the appropriate button. Pressing a button performs the action displayed next to it.</p> <p>As live display keys, you can assign up to four live displays. The live displays are copies of any live displays that you have set up in the controlling software.</p> <p>If the display is showing live displays you must toggle back to show the soft key functions if you want to use a soft key button on the control panel.</p> <p>For information on setting up the display and numbered buttons; refer to the controlling software’s On-line Help.</p>
<b>Jog Controls</b>	User control panel ( <a href="#">Figure 5</a> )	<p>These buttons actuate the piston of the hydraulic cylinder in the direction indicated. If the piston will not move AND the frame is equipped with a J3-style crosshead, be sure that the locks control switch is in the <b>Clamp</b> position.</p> <p>If you hold the button in, the adjustment speed increases linearly, up to a preset maximum, until you release the button.</p>
<b>FINE JOG</b> (or <b>FINE POSITION</b> )	User control panel ( <a href="#">Figure 5</a> )	Turn this thumbwheel for slow but accurate positioning of the piston within the hydraulic cylinder. <b>FINE JOG</b> allows you to set an accurate zero extension point, or to set a precise grip position for loading specimens. It can also be used to apply a controlled preload to specimens.
<b>ZERO EXTENSION</b> (or <b>RESET GL</b> )	User control panel ( <a href="#">Figure 5</a> )	<p>Press this button to set the current position of the piston as the zero extension point (or gauge length) position. After setting the zero extension point, the piston returns to this position when:</p> <ul style="list-style-type: none"> <li>The piston encounters a pre-set limit or event that instructs the piston to return to zero extension point</li> <li>You press the <b>RETURN</b> button (with Bluehill software only)</li> </ul>
<b>AT ZERO Indicator</b> (or <b>AT GL Indicator</b> )	User control panel ( <a href="#">Figure 5</a> )	This indicator illuminates when the piston is at the preset zero extension point. It will also illuminate when you press the <b>ZERO EXTENSION</b> button, which indicates that the current position of the piston is now the new zero extension point.

Table 9. Control functions. (Continued)

Control	Location	Description
<b>POWER Indicators</b>	User control panel (Figure 5)	This <b>POWER</b> indicator illuminates when power to the 59 Series control unit is on. Associated with this are <b>FRAME STANDBY</b> and <b>FRAME READY</b> indicators. Certain subsystems, such as the load cell and its conditioner board, require a somewhat lengthy warm-up time. In <b>FRAME STANDBY</b> , power is supplied to these subsystems but not to the HPS (frame is disabled). In <b>FRAME READY</b> , the system supplies power to all subsystems including the HPS (frame is enabled). The system is ready for operation.
<b>SPECIMEN PROTECT and Indicator</b>	User control panel (Figure 5)	<b>SPECIMEN PROTECT</b> is an electronic function that protects test specimens and load cells from overload during test setup. Press this button to toggle this function on and off. The <b>ON</b> indicator shows when <b>SPECIMEN PROTECT</b> is on and off. The indicator blinks when <b>SPECIMEN PROTECT</b> is on. <b>SPECIMEN PROTECT</b> must be set up in the controlling software before it can be turned on (see software manual or on-line help for information on setting this feature). Also, it can only be turned on when the frame/HPS is enabled.
<b>START TEST</b>	User control panel (Figure 5)	Press this button to begin the test once all test parameters are set. Up and Down Arrow indicators show the type of test selected (Up indicates tension and Down indicates compression). If the hydraulic cylinder will not move AND the frame is equipped with a J3-style crosshead, be sure that the locks control switch is in the <b>Lock</b> position.
<b>STOP TEST</b>	User control panel (Figure 5)	Press this button to stop motion of the piston at the end of the test, if it has not already been programmed at the computer.
<b>RETURN</b>	User control panel (Figure 5)	This function is dependent on the controlling software; refer to the controlling software's On-line Help.
<b>LOAD</b>	59 Series control unit	A female 25-pin interface that connects the system's load cell to the transducer conditioning card.
<b>STRAIN 1</b>	59 Series control unit	A female 25-pin interface that connects an extensometer to an optional transducer conditioning card.
<b>STRAIN 2</b>	59 Series control unit	A female 25-pin interface that connects an extensometer to an optional transducer conditioning card. (Typically only required for transverse strain or other dual extensometer setups.)
<b>SERVICE Display</b>	59 Series control unit	Provides an indication of self-tests that are performed by the controls when the system is powered up and is also an indicator of system status. System status is normal when the <b>T</b> indicator is green and the <b>A</b> indicator is blinking red.

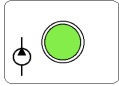

Figure 5. User control panel.

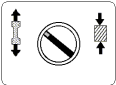
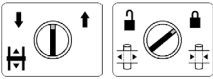
## Operation of HPS

The HPS is operated by controls on the front panel of frame base and the user control panel, and by functions within the controlling software. Methods to start and stop the HPS are provided in [Table 9](#) on page 27, “[Run a test](#)” on page 39 and “[Shut down the system](#)” on page 41.

When the HPS is on, the hydraulic cylinder should be positioned so that the piston is neither fully retracted nor fully extended. When the hydraulic cylinder is in either of these conditions, it is difficult for the 59 Series controls to maintain the position and the servo loop control could build up enough error to shut down the HPS.

## Isolation of HPS from the load frame

There may be some testing applications where it is desirable to isolate the Hydraulic Power Supply from the load frame. Examples would be applications where the testing is sensitive to vibration.

The following procedures isolate the HPS; the HPS rests directly on the floor and is no longer attached to the load frame.

### Procedure for 300LX frames

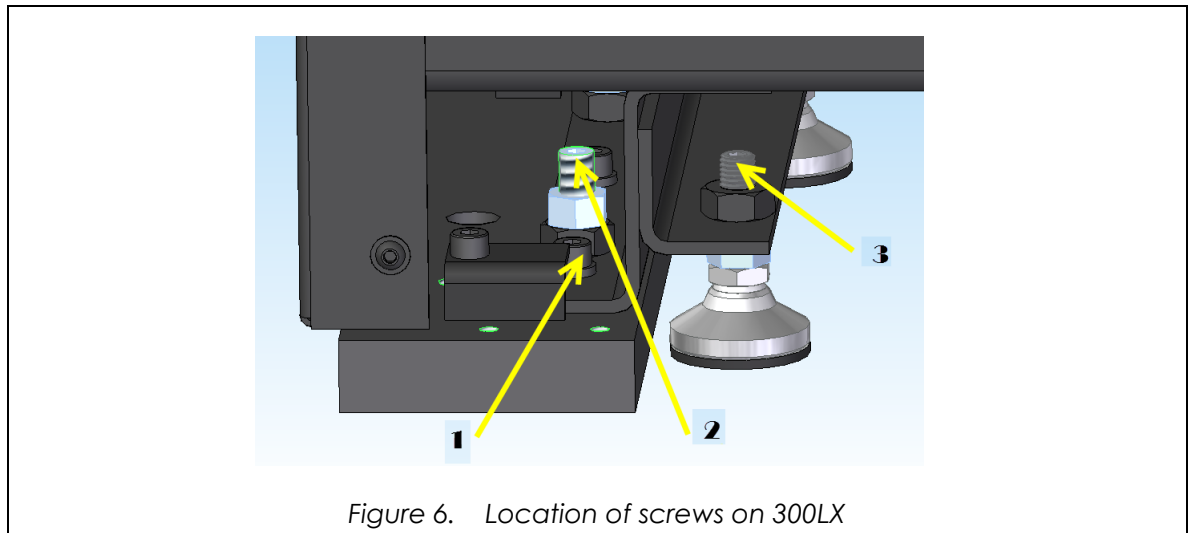

1. Power off the machine and disconnect the power cord.
2. Remove the rear and side panels from the base.
3. Using a 6 mm hex wrench, remove the mounting hardware (four black socket head cap screws from the left and right of the machine (No. 1 in [Figure 6](#)).
4. Loosen the lock nuts around the 4 set screws (No. 2 in [Figure 6](#)) to allow the set screws to turn.
5. Using a 6 mm hex wrench, rotate the 4 set screws (No. 2 in [Figure 6](#)) to raise the HPS so that it is clear of the frame mounting.
6. Using a 10 mm hex wrench, lower the leveling feet on the base of the HPS (No. 3 in [Figure 6](#)) so that the HPS is supported on the leveling feet.
7. Check clearances all around the base of the HPS. If any part of it is in contact with the frame base, use the set screws and leveling feet to make adjustments to avoid contact.

8. Remove the 4 set screws and lock nuts (No. 2 in [Figure 6](#)).
9. Reinstall the rear and side panels. Reconnect the power supply and power on the machine. Check for leaks and proper machine operation.

## Procedure for 600LX frames

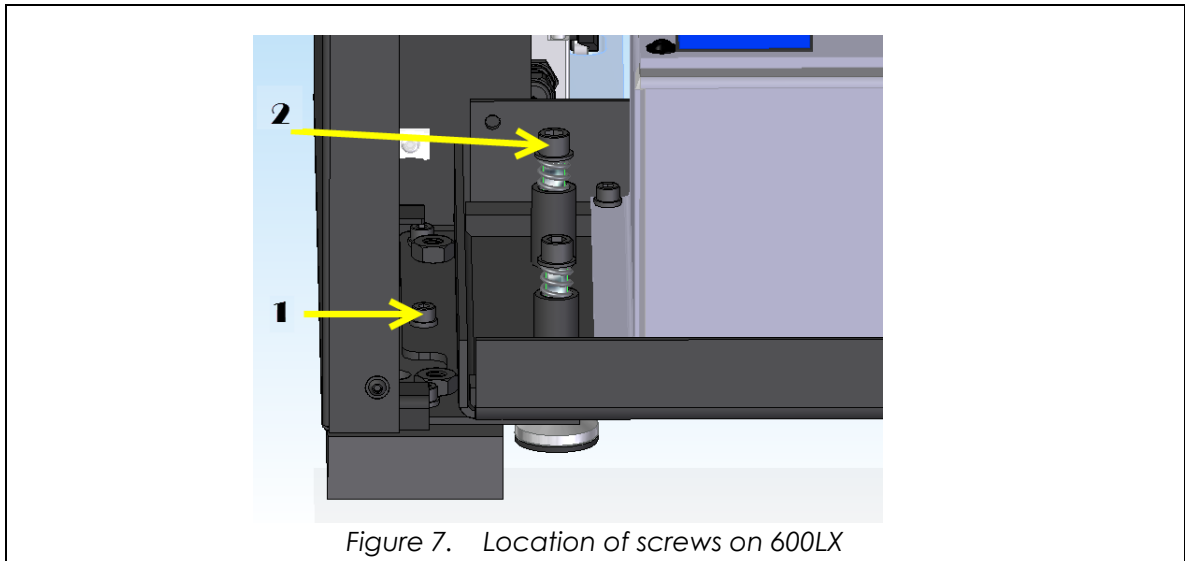

1. Power off the machine and disconnect the power cord.
2. Remove the rear and side panels from the base.
3. Using a 6 mm hex wrench, remove the mounting hardware (six black socket head cap screws from the left and right of the machine (No. 1 in [Figure 7](#)).
4. Using a 10 mm hex wrench, lower the leveling feet on the base of the HPS (No. 2 in [Figure 7](#)) so that the HPS is supported on the leveling feet.
5. Check clearances all around the base of the HPS. If any part of it is in contact with the frame base, use the leveling feet to make adjustments to avoid contact.
6. Reinstall the rear and side panels. Reconnect the power supply and power on the machine. Check for leaks and proper machine operation.

## Mount fixtures

### Warning

---



**Always wear appropriate personal protective equipment when preparing, operating and maintaining this equipment. Personal protective equipment should include, but is not limited to, eye protection and head protection. Other types of personal protective equipment may also be needed. You must perform your own risk assessment and take appropriate measures to protect yourself from harm.**

---





*Use of lifting or handling equipment (i.e. overhead crane, hoist, etc.) may be necessary to lift and install testing accessories. Many testing accessories weigh in excess of 15 kgs (30 lbs) and may be difficult for operators to install and remove from the frame. All of these considerations are the responsibility of the customer.*

The frame is supplied with multiple bolt patterns for the mounting of specimen load trains and testing accessories. Some bolt patterns are designed for the mounting of specific standard Instron accessories or fixtures, while others are more general for the mounting of a wide range of standard Instron accessories or fixtures. Any bolt pattern can be used for the mounting of customer fixtures; appropriate adaptation may be necessary. The capacity of any load train or accessory may be limited by the capacity of the bolt pattern being used. Most bolt patterns can accommodate testing at full frame capacity. Refer to the Note below.

Details of the bolt patterns provided on your frame can be found on the General Assembly drawing that is located in the separately supplied "Reference Manual-Equipment". General Assembly drawings are model specific; please be sure to refer to the appropriate drawing for your model and its configuration.



*Any bolt pattern that is six M10 x 1.5p tapped holes equally spaced on a 100 mm (3.937 in) bolt circle diameter can only accommodate low range tension testing up to 100 kN (22,500 lbs).*

## Start the system



*This document presumes that customer training (by Instron service personnel) has been completed and that at least one procedure has been created in the controlling software.*

Before operating the system:

- Familiarize yourself with the operating features and controls described in these instructions and in all other accompanying documentation for the controlling software.
- Verify that your system voltage is compatible with your power supply.

Following is the recommended procedure for system startup:

1. Be sure that the proper rating of main power is supplied to all system components and that all electrical cables are plugged in.
2. If the system includes an expansion channel module, turn the power switch on the rear of the module to ON ( | ).
3. Turn the system disconnect switch to ON ( | ).
4. Turn on power to all peripheral equipment that interfaces with the computer system. This includes the monitor, printer, any digital calipers, etc. Turn on power to the computer's CPU (central processing unit).
5. Check the display on the user control panel. The display shows an hour glass while the controls perform self-tests. Once the hour glass goes away, start the controlling software.



*While the controlling software and control electronics are booting up, do not press any control buttons. This could cause a failure during some of the self-test routines.*

6. Open or create the desired test procedure in the controlling software.
7. Check that the lights on the front of the 59 Series control unit are illuminated as follows:
  - **T** indicator of the **SERVICE** display is green
  - **A** indicator of the **SERVICE** display is blinking red



*If the **SERVICE** display flashes the letter "F" during startup, it indicates that an error has occurred. Refer to "Troubleshooting" in the System Concepts Manual (supplied separately) for more information.*

8. Check that the lights on the user control panel are illuminated as follows:
  - **POWER** is green
  - **FRAME STANDBY** is red
  - **TEST STOPPED** is red
9. Calibrate the load cell and let the system warm-up for at least 15 minutes to assure system stability, then re-calibrate.



*A fifteen minute warm-up period is also necessary whenever a load cell is changed, or after the initial connection of a strain gauge. After the warm-up period, the load cell or strain gauge must be calibrated.*

## Change height of test opening

### Warning



Always wear appropriate personal protective equipment when preparing, operating and maintaining this equipment. Personal protective equipment should include, but is not limited to, eye protection and head protection. Other types of personal protective equipment may also be needed. You must perform your own risk assessment and take appropriate measures to protect yourself from harm.

The height of the test opening can be changed. To change the height, adjust the position of the crosshead. The recommended procedures are provided in the following sections. Follow the appropriate procedure for the crosshead style of your frame.

### Warning



When adjusting the crosshead, be sure the crosshead is secured in place once it is positioned as desired:

- When the frame is equipped with a J1-style crosshead, be sure all retaining rings are properly in place and secured (see “[Adjust the position of a J1-style crosshead](#)”).
- When the frame is equipped with a J3-style crosshead, be sure that the crosshead support collars are positioned on the columns so they are in contact with the bottom of the crosshead and they are tightened to the required torque (see “[Adjust the position of a J3-style crosshead](#)”).

## Adjust the position of a J1-style crosshead

### Equipment required



All equipment must be supplied by the customer unless noted as “supplied”. For a list of equipment that was supplied with the system, refer to “[Ancillary parts](#)” on page 57.

- Lifting force - either the frame’s hydraulic cylinder (as detailed in procedure) or a crane or fork truck
- A suitable **stable** platform such as a man-lift, stairs, or ladder. The platform must be of sufficient height so that the operator can reach the Superbolt tensioners on the crosshead.
- A 5/16 in hex key (supplied)
- Blocks of lumber to support the crosshead
- A spanner wrench (supplied)

### Recommended procedure

1. [Start the system](#); see page 34. Start the HPS.
2. Extend or retract the hydraulic cylinder so that it has enough stroke in the appropriate direction to obtain the desired crosshead height:
  - **To lower the crosshead**, extend the hydraulic cylinder so that it has enough stroke to retract and lower the crosshead.

- **To raise the crosshead**, retract the hydraulic cylinder so that it has enough stroke to extend and lift the crosshead.
3. Place the lumber, as necessary, between the hydraulic cylinder and load cell. If fixtures are installed in the test space, the lumber can typically be placed between the fixtures without damage to them.
  4. Loosen and remove the collar (1a, [Figure 8](#)) from one of the threaded retaining rings (1) in the notch above the crosshead (use spanner wrench). This will expose the threaded sleeves (1b) of the retaining ring. Remove the threaded sleeves from the column and place them with their collar. Repeat to remove the other threaded retaining ring. **Be sure to keep the parts of each threaded retaining ring together as they are a matched set and should not be interchanged. If they are interchanged, the collar may not thread back on the sleeves properly and could become jammed.**
  5. Extend the hydraulic cylinder to raise the crosshead so that the split retaining rings (3) are exposed.
  6. Loosen the two socket head cap screws (SHCS) of one split retaining ring and remove the split retaining ring from the notch (use 5/16 in hex key). Repeat to remove the other split retaining ring.
  7. Operate the hydraulic cylinder until the lower surface of the crosshead is slightly above the desired notch.
  8. Place a split retaining ring into each new lower notch and tighten the socket head cap screws of each split retaining ring until seated plus one-quarter turn.
  9. Lower the crosshead to rest on the split retaining rings. The split retaining rings will fit into the recesses on the bottom of the crosshead.
  10. Place the two sleeves of one threaded retaining ring in the new upper notch of one column. A notch in the bottom edge of each sleeve will fit over a pin in the crosshead to ensure proper alignment (see [Figure 8](#)). Once the sleeves are in place, thread the collar onto the sleeves. Tighten the collar until seated plus one-quarter turn (use spanner wrench). Repeat to install the remaining threaded retaining ring on the other column.
  11. Retract the hydraulic cylinder and remove the lumber.
  12. Normal operation can now resume.

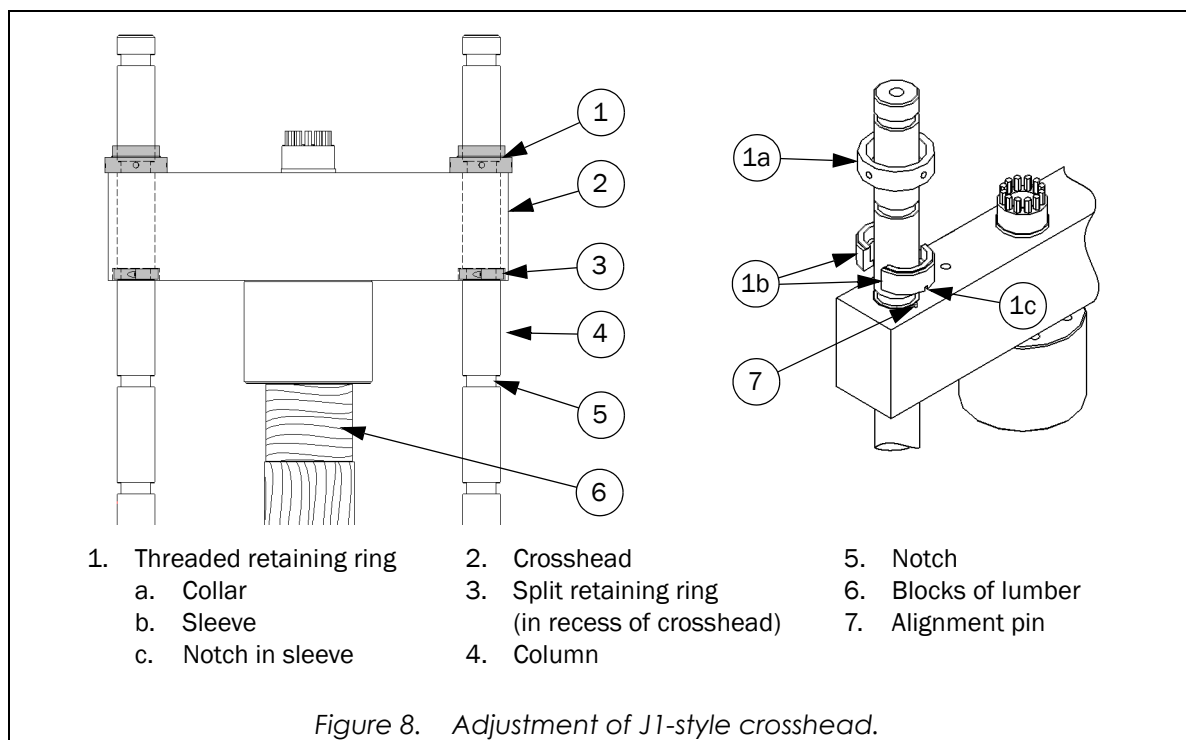

## Adjust the position of a J3-style crosshead

### Operation of controls

The crosshead lift and lock cylinders are operated by controls on the front of the frame base. The controls consist of a lifts control switch and locks control switch:

- **Lifts control switch** - This switch controls the operation of the crosshead lift cylinders. The crosshead must be unclamped before the crosshead can be adjusted. This switch is spring operated and will return to the neutral center position when released.
- **Locks control switch** - This switch controls the operation of the crosshead lock cylinders. This switch must be placed in the **Lock** position for testing. Only place it in the **Unlock** position when the crosshead is to be adjusted.

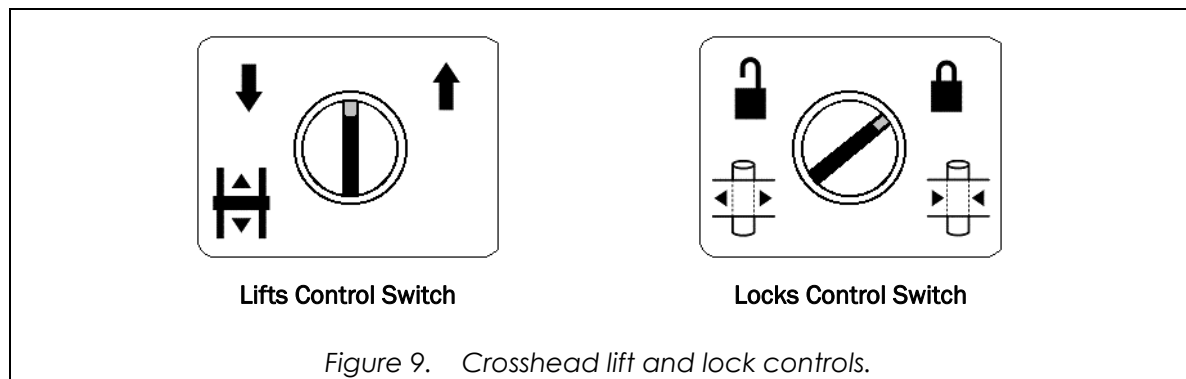

### Caution

Improper use of the crosshead lift cylinders can cause damage to the frame or installed accessories! Do not position the crosshead at either extreme of the lift cylinders (fully extended or fully retracted) unless specifically directed to do so by procedures in this manual. This can cause the crosshead to become unlevel and result in the following conditions:

- Any fixture or specimen installed in the frame may not align.
- If the crosshead is positioned with the crosshead lift cylinders fully extended and a tension or compression load is applied, the crosshead could slip until it reaches a level position.
- If the crosshead is positioned with the crosshead lift cylinders fully retracted and a tension load is applied, the crosshead will not be able to absorb the shock generated by a specimen break. This will cause the shock to be transferred to other components of the frame and may cause damage to the frame.

### Equipment required



All equipment must be supplied by the customer unless noted as “supplied”. For a list of equipment that was supplied with the system, refer to “Ancillary parts” on page 57.

- A suitable **stable** platform such as a man-lift, stairs, or ladder. The platform must be of sufficient height so that the operator can reach the crosshead.
- A 5/16 in hex-bit socket (supplied)

- A torque wrench (supplied)
- A ratchet wrench with 3/8 in square-drive

### Recommended procedure

1. [Start the system; see page 34.](#) Start the HPS.
2. Loosen the crosshead support collars so that they can slide along the columns (use hex-bit socket and ratchet wrench). Allow them to rest on the frame base.
3. Place the **Locks** switch in the **Unlock** position.
4. Place the **Lifts** switch in the **Up** or **Down** position to move the crosshead to the desired position. Release the switch to stop crosshead motion.
5. Place the **Locks** switch in the **Lock** position.



*Do not attempt to use the Jog controls to operate the hydraulic cylinder until approximately 1 minute has passed. This allows the HPS to build enough pressure to clamp the crosshead lock cylinders. The noise level of the HPS is a good indication of when this occurs; the noise level will decrease once it has built enough pressure and the crosshead lock cylinders are clamped.*

6. Adjust the crosshead support collars on the columns so that they are in contact with the bottom of the crosshead (use hex-bit socket and ratchet wrench). Secure the crosshead support collars to the columns. Tighten the cap screws to a torque of 68 N-m (50 lbf-ft) (use hex-bit socket and torque wrench).
7. Normal operation can now resume.

# Run a test

## Warning



Always wear appropriate personal protective equipment when preparing, operating and maintaining this equipment. Personal protective equipment should include, but is not limited to, eye protection and head protection. Other types of personal protective equipment may also be needed. You must perform your own risk assessment and take appropriate measures to protect yourself from harm.



*This information is NOT test specific, it is only intended to assist you in the general aspects of running a test. If you are testing to a specific standard or society specification (ASTM, ISO, EN, BS, etc.), those specifications should be obeyed with regard to number of tests run, specimen specifications, fixturing, inserting specimens and all other aspects of materials testing.*



*This document presumes that customer training (by Instron Service Engineer) has been completed and that at least one procedure has been created in the controlling software.*



*Refer to the supplied software manual for specific information about the controlling software. The following is only a general description of the necessary steps to run a test.*

Ensure that the following conditions are met before a test is run:

- The **LOAD** channel is calibrated.
- The **STRAIN** channel is calibrated if you are using an extensometer.
- You have reviewed the manuals for the controlling software and are familiar with the on-line help system that accompanies the software.
- Know the specific procedures to set up and run a test.
- The load transducer, grips and fixtures are appropriate for your test.

Following is the recommended procedure to run a test on a specimen:

1. If the system is not currently turned on, complete “[Start the system](#)” on page 34.
2. Verify that the setup and test parameters are reasonable and correct for your test.
3. Ensure that the displays on the user control panel illuminate.
4. Check that the frame is enabled.
5. Start the HPS. The **FRAME READY** indicator will illuminate. Immediately check the position of the piston within the hydraulic cylinder; the piston should be positioned so that it is neither fully retracted nor fully extended. If the piston is in either of these conditions, the servo loop control could build up enough error to shut down the HPS. Use the jog controls to move the piston if necessary - typically a separation of 6 mm (0.25 in) is sufficient.
6. Be sure that the **Tension/Compression** switch is in the correct position for the direction of the test.
7. Determine the required test opening and stroke needed to complete the desired test. Be sure to take into consideration the effective length of the fixtures that will be used, the length or height of the

specimen, and the expected change in length or height that the specimen will undergo during the test.

8. Determine if it is necessary to make any adjustments to the frame configuration to attain the required test opening that was determined in step 7. Raise or lower the crosshead as necessary - see the appropriate procedure for your frame under “[Change height of test opening](#)” on page 35.

## Warning



**When adjusting the crosshead, be sure the crosshead is secured in place once it is positioned as desired:**

- When the frame is equipped with a J1-style crosshead, be sure all retaining rings are properly in place and secured (see “[Adjust the position of a J1-style crosshead](#)”).
- When the frame is equipped with a J3-style crosshead, be sure that the crosshead support collars are positioned on the columns so they are in contact with the bottom of the crosshead and they are tightened to the required torque (see “[Adjust the position of a J3-style crosshead](#)”).

9. Install the desired specimen fixtures into the test space using adapters and alignment couplings as necessary.
10. Balance the load, if necessary.
11. Install the specimen into the fixtures as specified by your test method.
12. Install extensometry, strain gauges, etc. (if applicable).
13. Reset the zero extension point, if necessary.
14. Start the test.



*The test can be stopped at any time by using either the **STOP TEST** button on the user control panel or the **END TEST** button in the controlling software. This does not shut down the HPS unless the end test action in the software is set up to perform that task.*



*If it is necessary at any time to shut down the HPS, press the **DISABLE FRAME** button in the controlling software.*

15. As the test is running, the controlling software dynamically displays the data that is being collected or calculated for graphing and results. Also, the user may be prompted to perform some operation, such as remove an extensometer. When the operation has been performed, click the appropriate button to continue the test.
16. When the test is complete, the system will automatically stop the test as determined by the test procedure.
17. Remove the specimen and prepare the system for another test (as applicable).



*If the frame will sit idle between tests, press the **DISABLE FRAME** button in the controlling software to shut down the HPS. For added precaution, engage the **Emergency Stop** button to ensure that the HPS can not be inadvertently started. Release the **Emergency Stop** button when ready to run the next test. Once the HPS is running, immediately check the position of the piston within the hydraulic cylinder; the piston should be positioned so that it is neither fully retracted nor fully extended. Use the jog controls to move the piston if necessary - typically a separation of 6 mm (0.25 in) is sufficient.*



## Shut down the system

It is recommended that the system as a whole (frame, control unit, HPS, computer system, peripherals, etc.) be shut down at the end of each working day or anytime it will sit idle for long periods of time. The procedure to shut down the system is as follows:

1. Remove any specimen from the fixtures and jog the hydraulic cylinder so that the piston is fully retracted. For frames with J3-style crossheads, adjust the crosshead support collars on the columns so that they are in contact with the bottom of the crosshead. Secure the crosshead support collars to the columns. Tighten the cap screws to a torque of 68 N-m (50 lbf-ft). Also, refer to “[Loss of power](#)” on page 42.
2. Press the **DISABLE FRAME** button in the controlling software to shut down the HPS.
3. Engage the **Emergency Stop** button.
4. Exit the controlling software and any other software that is running. Shut down the Windows Operating System.
5. Turn off all peripheral equipment.
6. Turn the system disconnect switch to OFF ( **O** ).

If the frame will sit idle between tests, press the **DISABLE FRAME** button in the controlling software to shut down the HPS. For added precaution, engage the **Emergency Stop** button to ensure that the HPS can not be inadvertently started. Release the **Emergency Stop** button when ready to run the next test. Once the HPS is running, immediately check the position of the piston within the hydraulic cylinder; the piston should be positioned so that it is neither fully retracted nor fully extended. Use the jog controls to move the piston if necessary - typically a separation of 6 mm (0.25 in) is sufficient.

## Loss of power

If at any time main power is lost to the frame (due to the disconnect switch being turned off, **Emergency Stop** being engaged, power loss at the customer power supply, or complete power loss to facility), gravity will cause the frame to go to its natural resting state, i.e. the piston will retract into the hydraulic cylinder. The servo valve will prohibit oil leakage from the hydraulic cylinder. However, it can not stop 100% of oil leakage and thus the hydraulic cylinder will drift very slowly. Drift is slow enough that a noticeable amount of drift may be seen if system power remains off over an extended period (i.e. several days). Even with this very slow drift rate, multiple pinching hazards may exist on the frame (depending on accessories mounted in the test space) and personal injury is still possible. Also, any equipment laying on the base may be damaged. If possible, remove any specimens from the frame.

### Warning

---

---



**On loss of power, immediately remove hands and arms from the frame to avoid personal injury.**

---

### Caution

---

---

**On loss of power, any equipment in the test space may be damaged, particularly extensometers. It is always good practice to keep equipment that is not currently in use out of the test space.**

# Chapter 4

## Maintenance

---

- General maintenance recommendations ..... 43
- Preventative maintenance schedule ..... 43
- Make daily checks of system ..... 45
- Remove and install base covers ..... 46
- Electronics ..... 48
- Frame ..... 48
- Hydraulic power supply (HPS) ..... 50
- Ancillary parts ..... 57
- Consumable parts ..... 58
- Spare and replacement parts ..... 58

---

### Warning



Always wear appropriate personal protective equipment when preparing, operating and maintaining this equipment. Personal protective equipment should include, but is not limited to, eye protection and head protection. Other types of personal protective equipment may also be needed. You must perform your own risk assessment and take appropriate measures to protect yourself from harm.

## General maintenance recommendations

Only the maintenance procedures outlined in these instructions should be performed by the customer or their representative. All other maintenance and repairs should be performed by Instron Service personnel only.

## Preventative maintenance schedule

Table 10 outlines a recommended preventative maintenance schedule for system components.

Table 10. Recommended preventative maintenance schedule.

Frequency	Component	Maintenance Task
Daily:	System	<ul style="list-style-type: none"> <li>• <a href="#">Make daily checks of system; see page 45.</a></li> </ul>

Table 10. Recommended preventative maintenance schedule. (Continued)

Frequency	Component	Maintenance Task
<b>Monthly:</b>	System	<ul style="list-style-type: none"> <li>Visually inspect <b>all</b> hoses (exposed and hidden) and around the base of the frame for signs of oil leakage. Investigate any abnormal or excessive leakage and correct appropriately.</li> </ul>
	Frame	<ul style="list-style-type: none"> <li>For frames with a J3-style crosshead - <a href="#">Clean the columns; see page 50.</a></li> <li>Extend the hydraulic cylinder at least 150 mm (6 in) and then retract it the same distance. This will flush and lubricate the piston seal which extends its life.</li> </ul>
	HPS	<ul style="list-style-type: none"> <li>Check level of oil in reservoir and add oil as necessary. Refer to <a href="#">“Add oil to reservoir”</a> on page 50.</li> </ul>
<b>Biannually</b> (or once every 1000 hrs. of operation) <sup>1</sup> :	System	<ul style="list-style-type: none"> <li><a href="#">Inspect the hydraulic hoses; see page 55.</a></li> <li><a href="#">Inspect the cables; see page 48.</a></li> </ul>
	Frame	<ul style="list-style-type: none"> <li><a href="#">Inspect the hydraulic cylinder; see page 48.</a></li> <li><a href="#">Check operation of lift and lock cylinders of J3-style crosshead; see page 49.</a></li> </ul>
	HPS	<ul style="list-style-type: none"> <li><a href="#">Check the oil cleanliness; see page 50.</a></li> </ul>
	Electronics	<ul style="list-style-type: none"> <li><a href="#">Clean the fans; see page 48.</a><sup>2</sup>:</li> </ul>
<b>Annually</b> (or once every 2000 hrs. of operation) <sup>1</sup> :	System	<ul style="list-style-type: none"> <li>Verify/Calibrate system.</li> </ul>
	HPS	<ul style="list-style-type: none"> <li><a href="#">Change the air breather filter; see page 55.</a></li> <li>For <b>special</b> operating conditions where oil temperature is continuously between 60 and 80 deg. C (140 and 176 deg. F) - <a href="#">Change the oil; see page 53.</a></li> </ul>
<b>Biennially</b> (or once every 4000 hrs. of operation) <sup>1</sup> :	HPS	<ul style="list-style-type: none"> <li>For <b>normal</b> operating conditions where oil temperature is continuously below 60 deg. C (140 deg. F) - <a href="#">Change the oil; see page 53.</a></li> </ul>
<b>Every 5 years:</b>	System	<ul style="list-style-type: none"> <li><a href="#">Replace high pressure hydraulic hoses; see page 56.</a></li> </ul>
<b>Every 7 years:</b>	System	<ul style="list-style-type: none"> <li><a href="#">Replace low pressure hydraulic hoses; see page 56.</a></li> </ul>

1. Whichever is soonest.

2. The frequency listed here is only a recommendation. The correct frequency for your system is heavily dependent on the environmental conditions in which your system is used. Dirty environments may require a more frequent interval, while clean laboratory conditions could require less. We recommend beginning with the frequency listed here and then adjusting this frequency as experience dictates.

## Make daily checks of system

Before operating the system each day, a general check of the system is highly recommended. Performing a good general check on a daily basis is an important part of preventative maintenance. It also allows the operator to become familiar with the system, and with what is considered normal behavior and normal appearance. Once familiar with the system, operators will be more likely to notice any abnormalities that could indicate problems, or potential problems, with the system. Before operating the system each day:

- Check that the frame is square and not out of alignment. This can be a simple visual check. Stand away from the frame and check that all horizontal components (i.e. the table and crosshead) are parallel with each other and aligned vertically. Also check that all vertical components (i.e. the columns and, for frames with a J3-style crosshead, the lift cylinders) are parallel with each other and aligned horizontally. Misalignment indicates that a larger problem exists.
- Check that all testing fixtures (compression plates, bend fixtures, external tension accessories, adapters, etc.) are free of dirt, damage and deformation. Any fixture with damage or deformation should be corrected before use!
- For frames with a J1-style crosshead: Check the tightness of the socket head cap screws in the retaining rings that support the tension crosshead on the columns.
- Check that power is adequately supplied to the electronics. Start up the system and check all indicator lights on the user control panel, HPS controls and 59 Series control unit. Check that the lights are not too bright or too dim, and that they don't flicker. If any of these conditions exist, this could indicate a problem with the power supply in the 59 Series control unit or with system main power (customer supply).
- Visually inspect the following for signs of oil leakage. Investigate any leakage and correct appropriately. It is not necessary to remove any covers from equipment unless an oil leak is found.
  - Any **exposed** hydraulic hoses - this may indicate leakage from loose connections or from damaged hoses.
  - Around the base of the frame - this may indicate leakage from internal hydraulic connections, from the HPS, or from the hydraulic cylinder.  
Remove covers as necessary to investigate any oil leakage; see ["Remove and install base covers"](#) on page 46. If an oil leak is suspected from the hydraulic cylinder, see ["Inspect the hydraulic cylinder"](#) on page 48 for guidance.
- Check that all cables are free of wear and chafing, have adequate slack to prevent excessive strain on connectors, and have tight connections.

If any of these checks reveal a potential problem, the problem should be investigated and corrected **before** the system is operated. For assistance in troubleshooting the system, contact your local Instron Services department as directed on page 17.

## Remove and install base covers

To perform any maintenance on the electrical panel or HPS it is necessary to remove one or more of the base covers. The only equipment required is a 4 mm hex key (supplied).

### To remove the front cover:

1. Be sure all cables are disconnected from the 59 Series control unit on the right side of the base.
2. Loosen the four M6 button head cap screws (1, [Figure 10](#)) on the side of the base unit, at the front. It is not necessary to remove the cap screws, just loosen them.
3. Remove the two M6 flat head cap screws on the top of the base unit, at the front. One screw is shown as (2) in [Figure 10](#), the other is hidden behind the hydraulic control panel.
4. Pull the front cover forward to remove it.

To install the covers, perform the above procedures in reverse. Tighten all cap screws until fully seated plus one-quarter turn.

### To remove one or both side covers:

1. Remove the six M6 button head cap screws (3, [Figure 10](#)) on the rear panel of the base unit, three on each side. It is not necessary to remove the rear cover; it is still held in place by flat head cap screws through the top plate.
2. Loosen the four M6 button head cap screws (1, [Figure 10](#)) on the side of the base unit, at the front. It is not necessary to remove the cap screws, just loosen them.
3. Pull the side cover(s) toward the rear of the machine to remove them.

To install the covers, perform the above procedures in reverse. Tighten all cap screws until fully seated plus one-quarter turn.

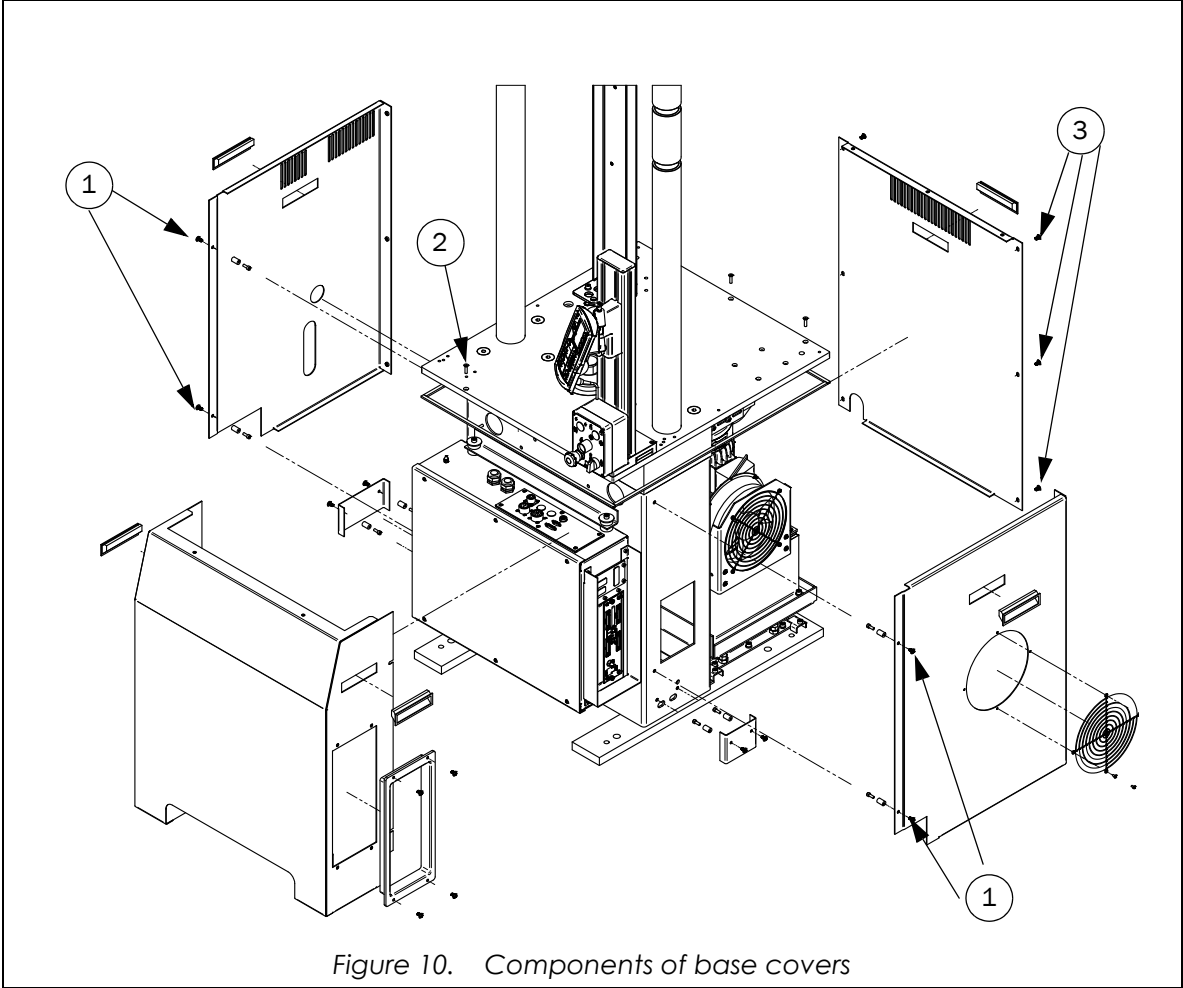

Figure 10. Components of base covers

## Electronics

To access any of the electronics, it is necessary to remove the front cover of the base. Refer to [“Remove and install base covers”](#) on page 46.

## Clean the fans

The fan opening of the computer system’s CPU should be cleaned at the frequency stated in the [“Preventative maintenance schedule”](#) on page 43. Use a vacuum to remove dust and dirt from the grill of the fan and the fan filter.

## Fuses

The system is equipped with one or more fuses. These fuses should only need replaced when they are blown. Refer to Chapter 4 of the System Concepts Manual (supplied separately) for more information on troubleshooting for a blown fuse.

## Inspect the cables

Cables should be inspected at the frequency stated in the [“Preventative maintenance schedule”](#) on page 43. Check the following:

- Inspect all cables for loose connections. This includes power cable and transducer cable connections at the frame and at the HPS. Tighten any loose connections that you may find.
- Inspect all cables for deterioration. Check for abrasions, cuts, etc. Replace cables as necessary.

If you notice any problems resulting from this inspection, contact your local Instron Services department as directed on page 17 for immediate assistance.

## Frame

### Warning



---

**Always wear appropriate personal protective equipment when preparing, operating and maintaining this equipment. Personal protective equipment should include, but is not limited to, eye protection and head protection. Other types of personal protective equipment may also be needed. You must perform your own risk assessment and take appropriate measures to protect yourself from harm.**

---

## Inspect the hydraulic cylinder

The hydraulic cylinder should be inspected at the frequency stated in the [“Preventative maintenance schedule”](#) on page 43. Perform the following:

- Check movement of the piston in the hydraulic cylinder. Use the jog controls to operate the hydraulic cylinder through its entire range of motion. Check for binding and abnormal noise. The piston should move smoothly. If you notice any problems resulting from this inspection, contact your local Instron Services department as directed on page 17 for immediate assistance.
- Inspect the hydraulic cylinder for signs of oil leakage. It will be necessary to remove the rear cover from the base in order to visually inspect the hydraulic cylinder (see [“Remove and install base](#)



[covers](#)” on page 46). After several years of use, it is normal to see some weeping or seeping of oil from the hydraulic cylinder. This small amount of oil can be cleaned and normal operation of the frame can continue. Excessive leakage that results in pooling of oil over a short period of time is abnormal; contact your local Instron Services department as directed on page 17 for immediate assistance.

- Clean the rod of the hydraulic cylinder. Completely extend the hydraulic cylinder and wipe the rod with a soft cotton cloth to remove oil residue and debris.

## Crosshead

The crosshead requires maintenance depending on the style of crosshead supplied with your frame. Refer to the following sections as appropriate.

### Check operation of lift and lock cylinders of J3-style crosshead

Frames that are equipped with a J3-style crosshead should have operation of the crosshead lift and crosshead lock cylinders checked at the frequency stated in the “[Preventative maintenance schedule](#)” on page 43. To check operation:



*Before checking operation of the crosshead lift and lock cylinders, you must be familiar with operation of the lift and lock cylinders. Refer to “[Adjust the position of a J3-style crosshead](#)” on page 37.*

### Equipment required



*All equipment must be supplied by the customer unless noted as “supplied”. For a list of equipment that was supplied with the system, refer to “[Ancillary parts](#)” on page 57.*

- A 5/16 in hex-bit socket (supplied)
- A torque wrench (supplied)
- A ratchet wrench with 3/8 in square-drive

### Recommended procedure

1. [Start the system; see page 30](#). Start the HPS.
2. Unclamp and clamp the crosshead lock cylinders. They should operate smoothly and quickly with no unusual noise. The Interlock status in the controlling software should indicate **Normal** when the crosshead is clamped.
3. Loosen the crosshead support collars so that they can slide along the columns (use hex-bit socket and ratchet wrench). Allow them to rest on the frame table.
4. Unclamp the crosshead lock cylinders and operate the crosshead lift cylinders to move the crosshead through its full range of motion. It should move smoothly with no unusual noise or erratic motion.
5. Return the crosshead to the desired operating position.
6. Clamp the crosshead lock cylinders.
7. Adjust the crosshead support collars on the columns so that they are in contact with the bottom of the crosshead (use hex-bit socket and ratchet wrench). Secure the crosshead support collars to the columns. Tighten the cap screws to a torque of 68 N-m (50 lbf-ft) (use hex-bit socket and torque wrench).

8. If you notice any problems resulting from this inspection, contact your local Instron Services department as directed on page 17 for immediate assistance.

## Clean the columns

**For frames with a J1-style crosshead**, it is generally not necessary to clean the columns on any regular interval, although it is recommended that you do not allow the columns to become overly dirty. They can be cleaned with a petroleum-based solvent or cleaner to remove dirt and oil.

**For frames with a J3-style crosshead**, it is necessary to clean the columns at the frequency stated in the “[Preventative maintenance schedule](#)” on page 43. The cleanliness of the columns will affect:

- How well the crosshead is clamped by the crosshead lock cylinders. Dirt and oil could allow the crosshead to slip.
- The life span of the wipers that are used in the crosshead. These wipers scrape away any dirt or debris that is on the columns and will deteriorate more quickly if the columns are not kept clean.

In most cases, it is sufficient to clean the columns with a petroleum-based solvent or cleaner to remove dirt and oil. If necessary, use steel wool or a ScotchBrite™ pad to remove heavy dirt or oil. Wipe the columns dry; any residue on the columns could prevent proper clamping of the crosshead. Do not apply any lubricant to the columns.

## Hydraulic power supply (HPS)

The HPS should be maintained according to the “[Preventative maintenance schedule](#)” on page 43.

## Check the oil cleanliness

The cleanliness of the oil in the reservoir should be checked at the frequency stated in the “[Preventative maintenance schedule](#)” on page 43. Check the appearance of the oil through the sight gauge; it should be a clear amber color. If the oil appears dirty, it should be changed (see “[Change the oil](#)” on page 53).



*In the United States and Canada, an oil sample test kit is available for purchase from Instron Services; contact your local Instron Services department as directed on page 17 for more information about the test kit.*

## Add oil to reservoir

It should only be necessary to add oil to the reservoir if an oil leak is evident. However, the oil level should be checked at the frequency stated in the “[Preventative maintenance schedule](#)” on page 43. Check the oil level through the sight gauge on the HPS. The oil should be to the top of the sight gauge when the frame’s hydraulic cylinder is fully retracted. When it is necessary to add oil, perform the following procedure.

## Equipment and supplies required



*All equipment and supplies must be supplied by the customer unless noted as “supplied”. For a list of equipment that was supplied with the system, refer to “[Ancillary parts](#)” on page 57.*

- A 4 mm hex key (supplied)
- A clean funnel with a mesh filter

- Clean towels, rags, or similar
- Hydraulic fluid (amount required depends on how much is needed to sufficiently fill reservoir), for fluid specifications see “[Oil type and quantity](#)” on page 56

## Recommended procedure

Refer to [Figure 11](#) on page 52 for identification of components.

1. Remove the right side cover from the frame base. Refer to “[Remove and install base covers](#)” on page 46.
2. Clean the area around the fill hole and air breather filter (3 and 2) to remove all dust, dirt and grime.
3. If the oil temperature/level switch has tripped and it is determined that the trip was caused by a low oil level, perform steps [b](#) through [d](#) of this procedure only. Otherwise, skip this step and continue with step [4](#).
  - a. Remove the air breather filter from the reservoir fill hole - push down and turn counterclockwise.
  - b. Insert the clean funnel with a mesh filter into the fill hole and add enough of the recommended hydraulic fluid to the reservoir until the oil is visible at the bottom of the sight gauge. This will reset the temperature/level switch.
  - c. Remove the funnel.
  - d. Install the air breather filter onto the reservoir fill hole.
4. Start the HPS and fully retract the hydraulic cylinder.
5. Press the **DISABLE FRAME** button in the controlling software to shut down the HPS.
6. Remove the air breather filter from the reservoir fill hole - push down and turn counterclockwise.
7. Insert a clean funnel with a mesh filter into the fill hole and fill the reservoir with the recommended hydraulic fluid. Fill the reservoir to the top of the sight gauge.
8. Install the air breather filter onto the reservoir fill hole.
9. Start the HPS and cycle the hydraulic cylinder through its full stroke a few times. Fully retract the hydraulic cylinder. Press the **DISABLE FRAME** button in the controlling software to shut down the HPS. Check the oil level. If the oil is not to the top of the sight gauge, repeat steps [6](#) through [9](#). If the oil is to the top of the sight gauge, continue with next step.
10. Install the cover that was removed in step [1](#).

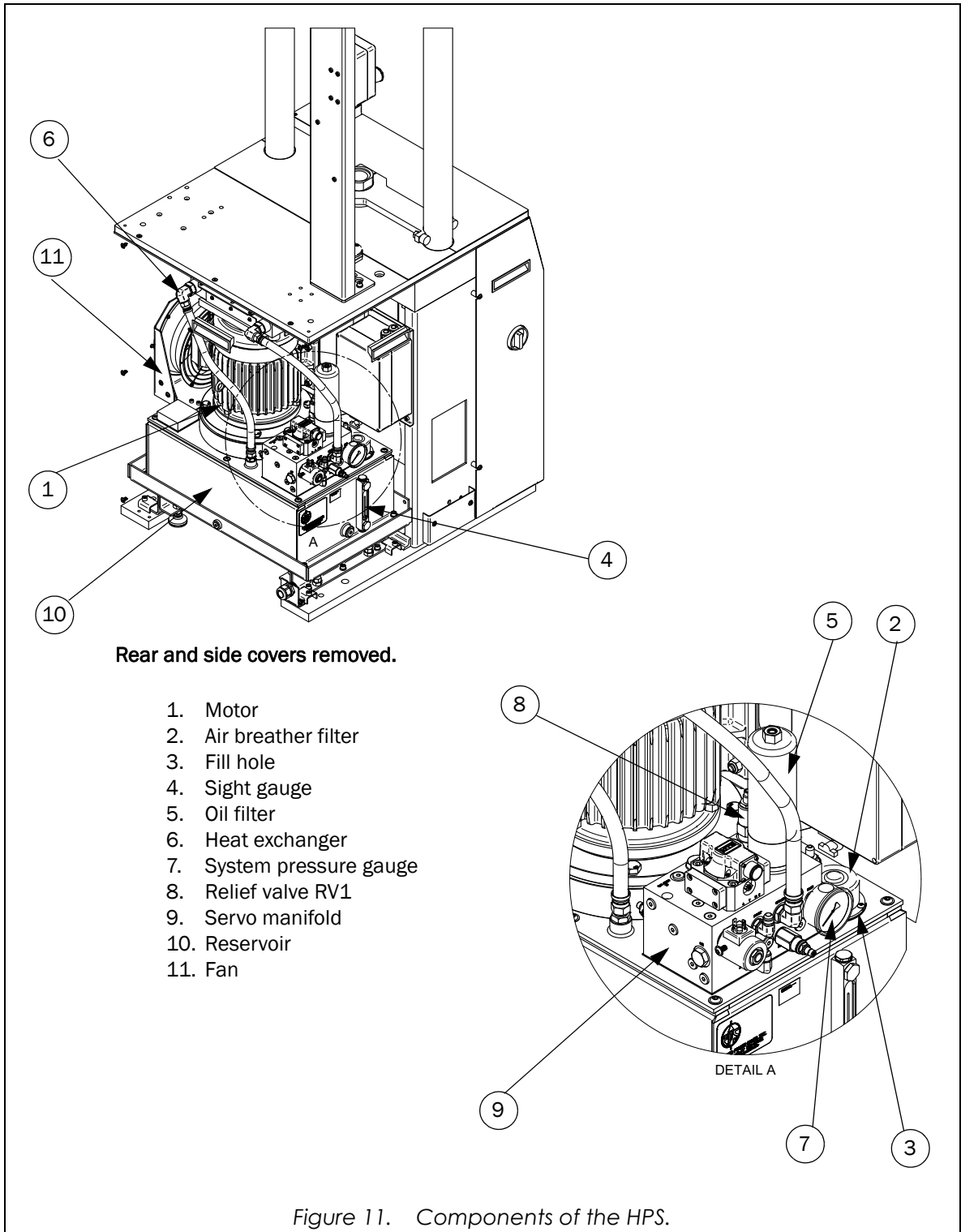

## Change the oil

The oil in the reservoir should be changed at the frequency stated in the “[Preventative maintenance schedule](#)” on page 43, or if the oil is determined to be dirty during a visual inspection (see “[Check the oil cleanliness](#)” on page 50). The oil filter should be changed every time that the oil is changed. The following procedure includes steps to change the oil filter.

### Equipment and supplies required

- A 3 mm hex key
- A 4 mm hex key
- A 9/16 in socket
- A 7/8 in socket
- A 1 in deep socket
- A ratchet wrench (for the sockets that are listed above - may also need a socket adapter depending on what the drive size requirements are)
- A torque wrench with range of at least 20 to 68 N-M (15 to 50 lbf-ft) (for the sockets that are listed above - may also need a socket adapter depending on what the drive size requirements are)
- A hand pump or similar to remove oil from reservoir
- A clean funnel with a mesh filter
- An oil container for collection of used oil
- Clean towels, rags, or similar
- Hydraulic fluid, for fluid specifications and amount required see “[Oil type and quantity](#)” on page 56
- New oil filter element - for Instron part number see [Table 13](#) on page 58
- New air breather filter - for Instron part number see [Table 13](#) on page 58

### Recommended procedure

Refer to [Figure 11](#) on page 52 for identification of components.

1. Remove the right side cover from the frame base. Refer to “[Remove and install base covers](#)” on page 46.
2. Start the HPS and fully retract the hydraulic cylinder.
3. Press the **DISABLE FRAME** button in the controlling software to shut down the HPS.
4. Change the oil filter:
  - a. Clean the outside surfaces of the filter and manifold (5 and 9) with a cleaning solvent to remove all dust, dirt and grime. Wipe dry with a clean towel.
  - b. Remove the vent plug from the top of the filter housing (use 9/16 in socket and ratchet wrench).
  - c. Locate relief valve “RV1” on the servo manifold (8). Loosen the relief valve (use 1 in deep socket and ratchet wrench). By hand, continue to loosen and slowly remove the relief valve. This allows oil to drain from the filter.
  - d. Wrap the relief valve in a clean towel to keep it clean, and set it aside.
  - e. Carefully loosen the filter housing (use 7/8 in socket and ratchet wrench). By hand, continue to loosen and slowly remove the filter housing.
  - f. Wrap the filter housing in a clean towel to keep it clean, and set it aside.

- g. Very gently remove the filter element. Oil from the inner part of the filter element will drain out and return to tank. Be careful not to shake any dirt off of the element and into the oil. Properly dispose of the filter element.
  - h. Inspect the filter cavity for damage. Wipe the filter cavity with a clean towel to remove all debris.
  - i. Install the new filter element. Carefully slide it over the bushing at the bottom of the filter cavity.
  - j. Inspect the filter housing and seals for damage. Wipe them with a clean towel to remove all debris.
  - k. Apply clean hydraulic oil to the threads of the filter housing (as a lubricant).
  - l. Install the filter housing over the filter element. Tighten the filter element by hand until you feel resistance from the seals. Change to the 7/8 in socket and ratchet wrench and continue to tighten the filter element until fully seated. Change to the torque wrench and tighten the filter housing to a torque of 61 N-m (45 lbf-ft).
  - m. Wipe the area around the port for the relief valve with a clean towel to remove all debris.
  - n. Carefully install the relief valve in the port. Tighten the valve by hand until it is seated in the port and you feel resistance from the seal. Continue to tighten the relief valve (use 1 in deep socket and torque wrench) to a torque of 34 N-m (25 lbf-ft).
  - o. Install the vent plug into the top of the filter housing (use 9/16 in socket and ratchet wrench) until snug and then back it out one full turn.
5. Purge air from the oil filter:
- a. Make sure the HPS is shut down.
  - b. Put towels around the base of the oil filter to absorb leaking oil.
  - c. Start the HPS and monitor the flow of oil from the vent plug. Watch for air bubbles in the oil. Run the HPS until there are no more air bubbles. Clean up any leaking oil.
  - d. Press the **DISABLE FRAME** button in the controlling software to shut down the HPS.
  - e. Tighten the vent plug (use 9/16 in socket and torque wrench) to a torque of 20 N-m (15 lbf-ft). Clean up any leaking oil.
  - f. Start the HPS and let it run for approximately ten minutes. While the HPS is running watch the oil filter and vent plug for oil leakage. If there is oil leakage, check and tighten the appropriate component.
  - g. When there is no oil leakage, cycle the hydraulic cylinder through its full stroke several times to ensure proper operation and to completely purge air from the system.
  - h. Press the **DISABLE FRAME** button in the controlling software to shut down the HPS.
6. Clean the HPS of all spilled and leaked oil. Clean the area around the fill hole and air breather filter (3 and 2) to remove all dust, dirt and grime.
7. Remove the air breather filter from the reservoir fill hole - push down and turn counterclockwise.
8. Remove the screws from the air breather fitting (use 3 mm hex key) on the reservoir. Remove the fitting and plastic screen from the reservoir fill hole.
9. Insert the hand pump hose into the reservoir.
10. Pump the oil out of the reservoir and into the oil container.
11. Install the air breather fitting and plastic screen into the reservoir fill hole. Secure the air breather fitting to the reservoir with the screws that were removed in step 8.
12. Insert a clean funnel with a mesh filter into the fill hole and fill the reservoir with the recommended hydraulic fluid. Fill the reservoir to the top of the sight gauge.

13. Install the air breather filter onto the reservoir fill hole.
14. Start the HPS and cycle the hydraulic cylinder through its full stroke a few times. Fully retract the hydraulic cylinder. Press the **DISABLE FRAME** button in the controlling software to shut down the HPS. Check the oil level. If the oil is not to the top of the sight gauge, repeat step 7 and then steps 12 through 14. If the oil is to the top of the sight gauge, continue with next step.
15. Install the cover that was removed in step 1.

## Change the air breather filter

The air breather filter should be changed at the frequency stated in the “[Preventative maintenance schedule](#)” on page 43.

## Equipment and supplies required

- New air breather filter - for Instron part number see [Table 13](#) on page 58



*When ordered from Instron, the air breather filter includes a new air breather fitting and plastic screen. The only part needed is the air breather filter. However, you can replace the existing air breather fitting and plastic screen with the new parts if desired or necessary (due to damage, etc.).*

## Recommended procedure

Refer to [Figure 11](#) on page 52 for identification of components.

1. Remove the right side cover from the frame base. Refer to “[Remove and install base covers](#)” on page 46.
2. Clean the area around the fill hole and air breather filter (3 and 2) to remove all dust, dirt and grime.
3. Remove the air breather filter from the reservoir fill hole - push down and turn counterclockwise. Properly dispose of the air breather filter.
4. Install the new air breather filter onto the reservoir fill hole.
5. Install the cover that was removed in step 1.

## Inspect the hydraulic hoses

Hydraulic hoses should be inspected at the frequency stated in the “[Preventative maintenance schedule](#)” on page 43. Check the following:

- Inspect all hose fittings for loose connections. This includes connections at the frame and at the HPS. Also be sure to check all hose fittings for any hydraulic accessories that are part of the testing system. Tighten any loose fittings that you may find.
- Inspect all hydraulic hoses for deterioration. Check for abrasions, cuts, etc. Replace hoses as necessary.

## Replace the hydraulic hoses

Hydraulic hoses should be replaced at the frequency stated in the “[Preventative maintenance schedule](#)” on page 43. The service life of any hydraulic hose depends on the pressure that it is subjected to during its normal use.

## Replace low pressure hydraulic hoses

Low pressure hoses are hoses that are normally subjected to pressures less than 20 bar (300 psi). Low pressure hoses would be:

- Drain hoses
- Return hoses between system components and the reservoir

## Replace high pressure hydraulic hoses

High pressure hoses are hoses that are normally subjected to pressures 20 bar (300 psi) and greater. High pressure hoses would be:

- Supply hose between the HPS and hydraulic cylinder
- For frames with a J3-style crosshead, any supply hose between the HPS and the crosshead lift cylinders and between the HPS and the crosshead lock cylinders

## Oil type and quantity

The International Standards Organization (ISO) viscosity designation for oil appropriate to use in the reservoir is ISO VG 32. An ISO VG 32 grade oil was used to fill the hydraulic reservoir before the equipment left the factory. As it becomes necessary to add to or replace the oil in the reservoir, use an ISO VG 32 grade oil. Many brand names contain this number. In general look for oils with the following properties: good demulsibility; low air entrainment; low pour point; and additives that protect against rust, corrosion, accelerated pump wear, foaming, and oxidation.

Approximate reservoir capacities for the various models of LX frames can be found in [Table 11](#).

*Table 11. Approximate capacity of HPS reservoir.*

Frame Model	Reservoir Capacity
300LX	34 L (9 gal)
600LX	34 L (9 gal)



## Ancillary parts

LX systems are provided with operating tools and other accessories that are either: required to complete installation of the frame; required for use or maintenance of frame; or required for set up of accessories on the frame. These ancillary parts are included with the frame upon delivery. Ancillary parts for the various LX systems are listed in [Table 12](#). Be sure to keep these ancillary parts in a safe place so they do not get misplaced.

Table 12. Ancillary parts list.

Description	Location or Purpose	Frame Model	Part Number <sup>1</sup>	Quantity
Isolation pad set, 4 in square	Frame installation	All	300-8899-10650	1
Hex-bit socket, 22 mm, 3/4 in square-drive	Loosen the clamp bolts during frame installation	300LX-J3 600LX-J3	300-8875-9406	1
Spanner wrench	Remove collar from the split retaining rings on the columns when adjusting crosshead height.	300LX-J1	300-8875-9370	1
		600LX-J1	300-8875-9345	1
Hex-bit socket, 5/16 in, 3/8 in square-drive	Tighten and loosen the crosshead support collars	300LX-J3 600LX-J3	300-8875-9428	1
Torque wrench, 3/8 in square-drive 14-115.8 N-m (8.3-83.3 ft-lbs)	Tighten crosshead support collars	300LX-J3 600LX-J3	300-8875-9277	1
Hex key set, 13 piece, 0.050 - 3/8 in ball end	Tighten and loosen various fasteners	All	300-8875-1958	1
Hex key set, 9 piece, 1.5 - 10 mm ball end	Tighten and loosen various fasteners	All	300-8875-9290	1

1. Part numbers are listed for reference only. Some parts can not be ordered using these numbers; contact your local Instron Services department as directed on page [17](#) to order parts.

## Consumable parts

LX systems are designed to require very few parts to be replaced during their lifetime. These consumable parts are listed in [Table 13](#). The replacement frequency of each part, or the condition that indicates that replacement is necessary, is discussed throughout this chapter.

Table 13. Consumable parts list.

Description	Location or Purpose	Frame Model	Part Number <sup>1</sup>
Oil filter element (3 micron)	HPS - oil filter	All	300-8873-9150
Air breather filter	HPS - reservoir	All	300-8868-9091

1. Part numbers are listed for reference only. Some parts can not be ordered using these numbers; contact your local Intron Services department as directed on page [17](#) to order parts.

## Spare and replacement parts

The Intron Services department can supply parts for your system. In the event that your system requires replacement parts, or if you choose to keep spare parts in stock, please contact your local Intron Services department as directed on page [17](#) for the proper part.

# Appendix A

## CE Certificate



**Industrial Products Group**  
900 Liberty Street ■ Grove City, PA 16127-9005  
Tel: +1-724-458-9610 ■ Fax: +1-724-458-9614

www.instron.com

### EC Declaration of conformity for machinery

(Machinery Directive 2006/42/EC, Annex II., sub. A)

Manufacturer: Instron, a division of Illinois Tool Works, Inc. - Industrial Products Group  
Address: 900 Liberty Street, Grove City, PA, 16127, USA

Name and address of the person authorised to compile the technical file:

Name: Jonathan Snell  
Address: Instron - Division of ITW Limited, Coronation Road, High Wycombe, Buckinghamshire, HP12 3SY, United Kingdom

Herewith we declare that

Model Number:  
Serial Number:

- is in conformity with the relevant provisions of the Machinery Directive (2006/42/EC)
- is in conformity with the provisions of the following other EC-Directives  
Low Voltage Directive 2014/35/EU  
EMC Directive 2014/30/EU

And furthermore, we declare that

- the following (parts/clauses of) European harmonised standards published in the Official Journal have been used

BS EN 60204-1: 2006	Safety of Machinery, Electrical Equipment of Machines
EN ISO 12100: 2010	Safety of machinery - General principles for design - Risk assessment and risk reduction
EN ISO 13849-1: 2008	Safety of machinery - Safety-related parts of control systems - Part 1: General principles for design
BS EN 61326-1: 2006	Electrical Equipment for Measurement, Control and Laboratory Use - EMC Requirements
- the following (parts/clauses of) other European harmonised standards, technical standards and specifications have been used

Place of Issue: Grove City, PA USA  
Date of Issue:

Signature:

A handwritten signature in black ink, appearing to read "Stephen A. Sample".

Stephen A. Sample  
R&D Engineering Manager

Supplier's declaration of conformity (in accordance with ISO/IEC 17050-1)

This page is intentionally blank.



The background of the page is an abstract composition of soft, flowing curves in shades of light gray and white. A prominent feature is a pattern of small, light gray dots arranged in a grid, which is partially obscured by the larger, smoother curves. The overall aesthetic is clean, modern, and technical.

Product Support: [www.instron.com](http://www.instron.com)