

2732-006 SERIES

High Temperature Pneumatic Action Grips

High temperature pneumatic action grips provide a convenient method for clamping delicate films, polymers and woven fabric within a temperature controlled environment. The clamping mechanism can be activated either automatically or through a foot switch. This allows hands-free grip closure enabling the specimen to be held with both hands for easy loading. High temperature pneumatic grips provide selectable clamping force to accommodate for the variety of different materials to be tested. Both jaw face automatically adjust to different specimen thickness to ensure that the line of tensile force remains concentric with the grip body. This has an excellent follow-up action that compensates for decay of the holding force due to specimen creep. The grips can be equipped with a selection of interchangeable grip jaw faces in various sizes and choice of surfaces including smooth ground, rubber-coated and serrated. Line contact and special coated faces are also available.

PRINCIPLE OF OPERATION

Pneumatic action grips clamp the specimen through a dual lever arm, actuated by air cylinders built into the grip body. The air cylinders are connected to pullrod extensions for fitting inside the temperature chamber. The air input to the grips is passed through hollow pullrods via a connection outside of the chamber. The gripping force can be increased with air pressure to accommodate materials that are often difficult to hold. This constant gripping force is maintained on the specimen and provides the ultimate in 'follow-up' action to compensate for any decay in the gripping force. The grips may be closed or opened by a pneumatic footswitch for hands-free operation. An automated air kit is also available for hands-free, automated and pretension testing. The interchangeable jaw faces are held on the grip in a manner that one face is free to swivel on a horizontal axis and the other on a vertical axis. This action allows for self-alignment to compensate for variations in sample thickness.

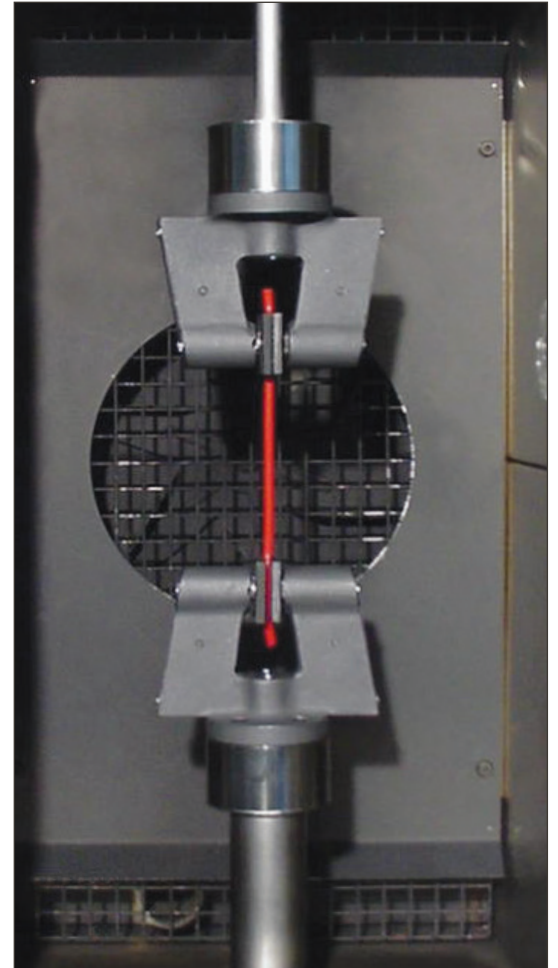

FEATURES AND BENEFITS

- Rated capacity: 100 N (10 kgf, 22 lbf)
- Open front design to facilitate specimen loading
- Self-centering action allows different specimen thickness without adjustment
- Pneumatic clamping of the specimen with follow-up action to reduce slippage
- Rugged design for minimum maintenance
- Adjustable gripping force
- Interchangeable jaw faces suitable for gripping different types of materials
- Rectangular jaw faces may be mounted with the long axis either horizontal or vertical to accommodate various specimens
- Temperature range: -70 °C to +316 °C (-100 °F to +600 °F)
- Optional automatic air kit with pretension and remote control for easy loading and improved efficiency

APPLICATION RANGE

- Type of loading: Tension*
- Specimen material: Thin sheets, films, foils, threads, plastic tapes, fine wires and soft materials
- Specimen shapes: Round (wires) and flat specimen with/without shoulder tab ends

*Not suitable for through zero/reverse stress or fatigue testing.

SPECIFICATIONS

Maximum Capacity	kN	0.1
	kgf	10
	lbf	22

Mechanical Connection

Upper Fitting	mm	3/16 in Clevis Pin (Type Bm)
Lower Fitting	mm	Pneumatic Connection
Overall Width (A)	mm	136
	in	5.3

Effective Length (B)

Upper Grip	mm	560
	in	22
Upper Grip (B1)	mm	100
	in	3.9
Lower Grip	mm	134
	in	5.3
Throat Depth (C)	mm	47
	in	1.8
Throat Depth (D)	mm	17
	in	0.7
Weight Per Grip	kg	0.42
	lbs	0.92
Temperature Range	°C	-70 to +316
	°F	-100 to +600
Clamping Force	kN	1.8
	kgf	180
	lbf	360
Maximum Air Pressure	bar	6.3
	PSI	90
Working Principle		Dual Pneumatic Side Action Clamping

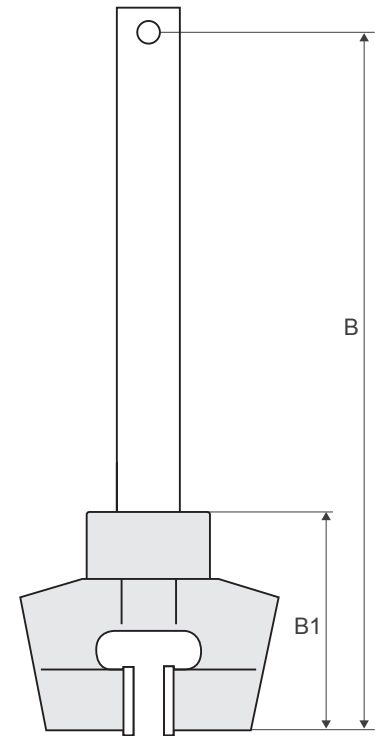

Upper Grip Dimensions

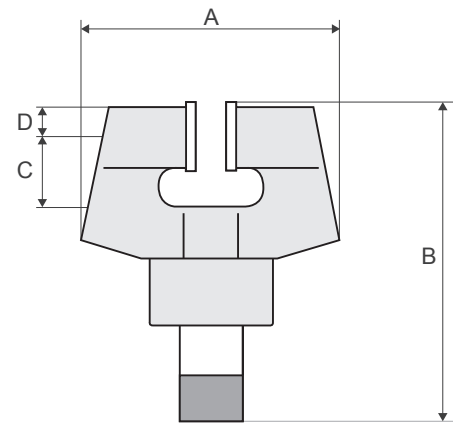

Lower Grip Dimensions

Notes:

1. Grip catalog number provides two grips
2. Upper grip has integrated pneumatic pullrod and may require mechanical attachment coupling to connect to the load cell
3. Upper grip may require a flexible coupling for certain applications
4. The lower grip requires the use of a pneumatic pullrod
5. Automatic air control kit, or pneumatic footswitch will be required for operation of these grips

ACCESSORIES

2810-018	Air compressor, portable 115 VAC
2810-060	Air compressor, portable 230 VAC
2701-004	Pneumatic footswitch
2701-065	Automatic air control kit for 4400, 5500 (excluding 4411) and upgrade (excluding 1130, 6000, 4500 and TTs)
2701-067	Automatic air control kit for 4411 and upgrades on 1130s

PULLRODS AND ADAPTORS

3119-305	Lower pullrod: Rated capacity 10 kN Mechanical fitting: 1/2 in clevis pin (Type Dm) to pneumatic connection Effective length: 81 mm (3.2 in)
3119-306	Lower pullrod: Rated capacity 10 kN Mechanical fitting: 1/2 in clevis pin (Type Dm) to pneumatic connection

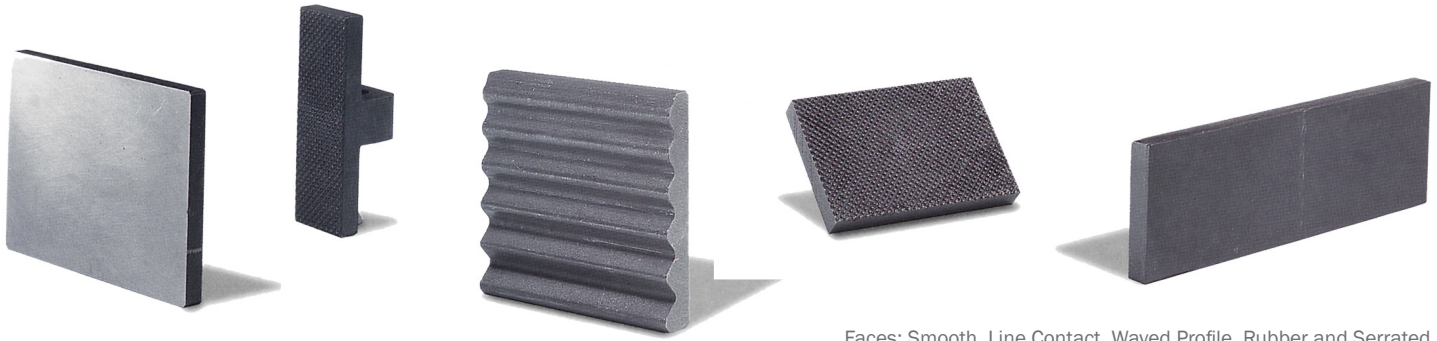

JAW FACES

Faces: Smooth, Line Contact, Waved Profile, Rubber and Serrated

Catalog Number	Specimen Thickness		Surface	Clamping Area (w × h)		Application
	mm	in		mm	in	
2702-001	0 - 3.2	0 - 0.125	Smooth Ground	12 × 25	0.5 × 1	For Gripping Thin Sheets, Films, Foils, Paper and Tapes
2702-004	0 - 3.2	0 - 0.125	Smooth Ground	25 × 25	1 × 1	For Gripping Thin Sheets, Films, Foils, Paper and Tapes
2702-007	0 - 3.2	0 - 0.125	Smooth Ground	50 × 25	2 × 1	For Gripping Thin Sheets, Films, Foils, Paper and Tapes
2702-002	0 - 3.2	0 - 0.125	Rubber-Coated	12 × 25	0.5 × 1	For Gripping Threads, Fabrics, Plastic Tapes and Fine Wires
2702-005	0 - 3.2	0 - 0.125	Rubber-Coated	25 × 25	1 × 1	For Gripping Threads, Fabrics, Plastic Tapes and Fine Wires
2702-008	0 - 3.2	0 - 0.125	Rubber-Coated	50 × 25	2 × 1	For Gripping Threads, Fabrics, Plastic Tapes and Fine Wires
2702-003	0 - 3.2	0 - 0.125	Diamond-Serrated, Pitch 1 mm (25-Teeth per in)	12 × 25	0.5 × 1	For Gripping Plastic and Soft Materials
2702-009	0 - 3.2	0 - 0.125	Diamond-Serrated, Pitch 1 mm (25-Teeth per in)	25 × 25	1 × 1	For Gripping Plastic and Soft Materials
2702-009	0 - 3.2	0 - 0.125	Diamond-Serrated, Pitch 1 mm (25-Teeth per in)	50 × 25	2 × 1	For Gripping Plastic and Soft Materials
2702-010	0 - 3.2	0 - 0.125	Line Contact ³	25 × 2.3 Radius Convex Surface	1 × 0.09 Radius Convex Surface	For Gripping Elasticated Fabrics, Paper and Rigid Plastic Films
2702-042	0 - 3.2	0 - 0.125	High Friction Compound	25 × 25	1 × 1	For Gripping Bundled Reinforced Plastics and Other Materials at Elevated Temperatures
2702-043	0 - 3.2	0 - 0.125	High Friction Compound	50 × 25	2 × 1	For Gripping Bundled Reinforced Plastics and Other Materials at Elevated Temperatures

Notes:

1. Faces catalog number provides four faces
2. All faces are hardened Rc to 60-65, excluding rubber-coated and if otherwise specified
3. Line contact jaw faces are supplied with smooth ground opposing face
4. The width and height of the faces are interchangeable, providing that one half of the vertical dimension of the face is less than dimension C

www.instron.com



Worldwide Headquarters
825 University Ave, Norwood, MA 02062-2643, USA
Tel: +1 800 564 8378 or +1 781 575 5000

European Headquarters
Coronation Road, High Wycombe, Bucks HP12 3SY, UK
Tel: +44 1494 464646