

±3 kN, ±25 Nm MECHANICAL FATIGUE-RATED WEDGE ACTION GRIPS

2742-206

Designed to suit ElectroPuls® test instruments, the 2742-206 mechanical wedge action grips are suitable for tension, compression, torsion and reverse-stress testing on a wide range of specimens and materials. The grips are mechanically operated and the open-fronted design provides easy specimen insertion, positioning, and clamping.

PRINCIPLE OF OPERATION

The bearing-assisted wedge action on the grips allows for easy and tool-less tightening of the grips. Where it may be necessary, this can also be done using a tommy bar or wrench. In both cases this adjustment is done without altering the vertical position of the faces in relation to the specimen. This Instron® design of a moving grip body, not jaw face, makes it possible to pre-select the exact point at which the specimen is gripped, with a consistent gauge length and with no compressive force being applied, which may cause specimen buckling. The open front design allows for quick and easy changing of the jaw faces. The jaw faces are serrated for optimum gripping performance and the serrations are designed to minimize damage to the specimen surface. Pullrods are also available to use for temperature testing.

APPLICATION RANGE

- Types of loading: Tension, compression, torsion, or reverse-stress testing
- Specimen geometries: Flat or round specimens
- Specimen material: Metallics, plastics, composites, biomaterials
- Temperature range: -70 to +350 °C (-94 to +662 °F)



±3 kN, ±25 Nm mechanical fatigue-rated wedge action grips

FEATURES

- Dynamic Linear Capacity: ±3 kN (±674 lbf)
- Dynamic Torque Capacity: Up to ±25 Nm (±221 lbs.in)
- Modular flange mounting design is directly compatible for use on all new E3000 and E10000 variants
- Optimized range of operation when used in a 3119-605 chamber with 3117-080 pullrod kit
- Suitable for linear and torsion, including full reverse-stress dynamic testing
- Open-fronted design for quick and easy specimen insertion from the side
- Self-tightening wedge design eliminates slippage and prevents specimen loading
- Interchangeable jaw faces for gripping different materials and specimen sizes
- Tool-less and easy grip operation
- Additional gripping force can be achieved using a tommy bar or wrench
- Secure operation due to built-in adjusters that ensure there is no rotary backlash

SPECIFICATIONS

Catalogue Number		2742-206
Maximum Force Capacity	kN	±3
	lbf	±674
Maximum Torque Capacity	Nm	±25
	lbf.in	±221
Grip Mass	kg	3.5
	lbs	7.27
A	mm	124
	in	4.88
B	mm	161
	in	6.34
C	mm	154
	in	6.06
D	mm	90
	in	3.54
E	mm	40
	in	1.57
F	mm	49
	in	1.93
G	mm	62
	in	2.44

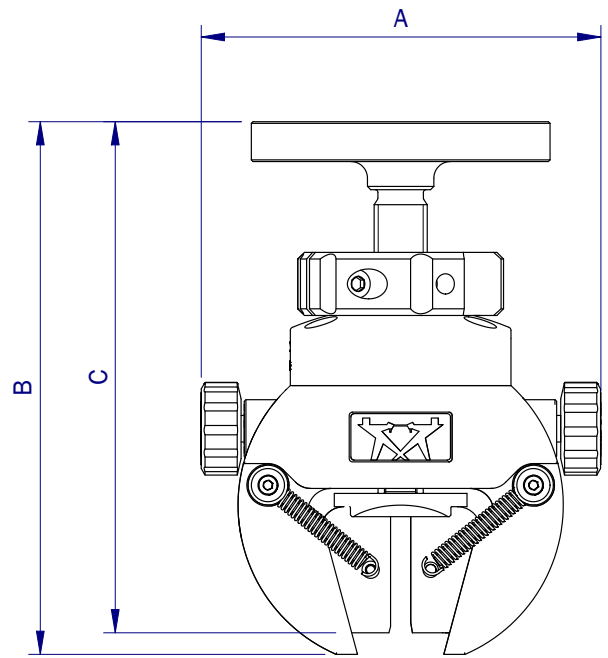

Grip Dimensions

JAW FACES

Catalog Number	Specimen Type	Specimen Thickness		Clamping Area (W x H)
		mm	in	
2703-801	Flat	0 to 6.3	0 to 0.25	25 mm x 38 mm (1.0 in x 1.5 in)
2703-802	Flat	6.3 to 12.7	0.25 to 0.50	25 mm x 38 mm (1.0 in x 1.5 in)
2703-803	Round	Ø 3.0 to 7.8	0.12 to 0.31	25 mm x 38 mm (1.0 in x 1.5 in)
2703-804	Round	Ø 7.1 to 12.7	0.28 to 0.50	25 mm x 38 mm (1.0 in x 1.5 in)
2703-807	Round	Ø 12.4 to 18.0	0.49 to 0.71	25 mm x 38 mm (1.0 in x 1.5 in)

- Notes: 1. Jaw face catalogue number provides four faces
 2. Jaw faces are hardened to 48 to 52 Rc, unless otherwise specified
 3. All faces are diamond serrated 45°

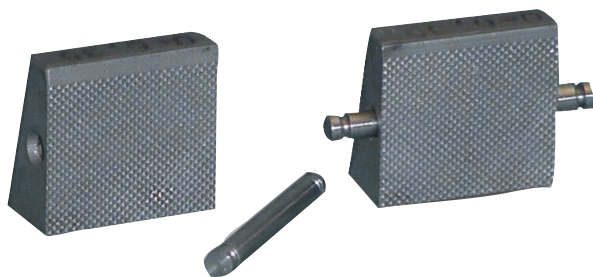
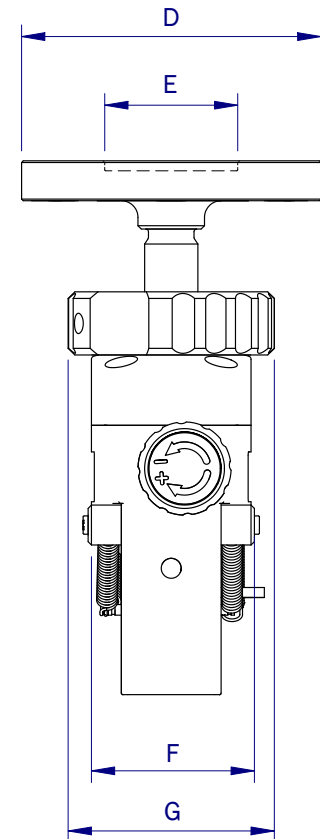

Flat Serrated Jaw Faces

www.instron.com



Worldwide Headquarters
 825 University Ave, Norwood, MA 02062-2643, USA
 Tel: +1 800 564 8378 or +1 781 575 5000

European Headquarters
 Coronation Road, High Wycombe, Bucks HP12 3SY, UK
 Tel: +44 1494 464646

CEAST Headquarters
 Via Airauda 12, 10044 Pianezza TO, Italy
 Tel: +39 011 968 5511