



The difference is measurable®

LONG TRAVEL XL EXTENSOMETER

Catalog Numbers 2603-080, 084, 085, 086

The Instron® model XL (long travel) extensometer is a precise device for measuring strain in highly extensible materials such as elastomers, semi-rigid plastics and films. Designed for use in electromechanical testing instruments, Instron XL units can be used to measure specimens elongation's up to 30 in or 750 mm.

Principle of Operation

The high elongation extensometer is designed to clamp directly onto a specimen quickly and easily. It will adjust to incremental gauge lengths ranging from 0.5 in to 5 in or 10 mm to 200 mm. The XL will accommodate up to 10 in of clamp displacement and is specifically designed to permit testing the sample through rupture without damaging the extensometer or otherwise disrupting the test routine. The XL extensometer is based on a pair of carefully counter balanced clamp assemblies which drive a potentiometer through connecting cables. Both clamps move freely but any increase in the separation or differential motion will advance the transducer. The upper and lower specimen clamps are separately counterbalanced and guided on a polished and ground shaft with linear bearings so that none of the extensometer's weight is applied to the specimen.

Features

- Quick release clamps
- Counterbalanced for minimum force on sample
- Variable gauge lengths settings
- Adjustable clamping pressure for a variety of specimen thickness'
- Easily installed on most Instron machines
- Self-identifying for ease of calibration
- SI, US and metric calibration units

Application Range

- Elastomeric testing
- Plastics testing
- Testing of material having high elongation properties
- Cellular materials



Specification Table

Catalog Number		2603-080/084	2603-085/086
Full Scale Travel	mm	250	750
	in	10	30
Extension Resolution	μm	100	250
	in	0.004	0.01
Extension Accuracy (Extensometer Only)	μm	± 200 or $\pm 0.75\%$ of extension	± 500 or $\pm 1\%$ of extension
	in	± 0.008 or $\pm 0.75\%$ of extension	0.02 or $\pm 1\%$ of extension
General Specifications			
Gauge Length Setting	mm	Graduated bar with marks at 10, 20, 25, 50, 100	
	in	Graduated bar with marks at 0.5, 1.0, 2.0	
Gauge Length Accuracy	μm	± 250 at 20 °C	
	in	± 0.01 at 20 °C	
Maximum Specimen Width	mm	20	
	in	0.75	
Maximum Specimen Thickness	mm	12.7	
	in	0.5	
Specimen Gripping Force - Thin Specimens	N	5 to 15	
	g	500 to 1500	
Operating Force	N	0.15	
	g	15	
Maximum Common-Mode Travel	mm	820	
	in	32.25	
Overtravel Protection	-	Mechanical limit stops, rotating clamp rods	
Bridge Resistance	W	350 (nominal)	
Excitation	Vrms	5	
	Hz	375 to 5000	
FS Sensitivity	m V/ V	2.5	
	%	± 4	
Balance	%	$< \pm 10$ of full scale	
Temperature Range	°C	10 to 38	
Frequency Response	-	Static applications only	
Weight of Extensometer	kg	5.0	
	lb	11.0	
Overall Height (H)	mm	1125	
	in	44.3	
Overall Length (L)	mm	280	
	in	11.0	
Width (W)	mm	130	
	in	5.1	
Reach of Arms	mm	157 to 167 (164 from center of guide rod)	
	in	6.2 to 6.6 (6.5 from center of guide rod)	

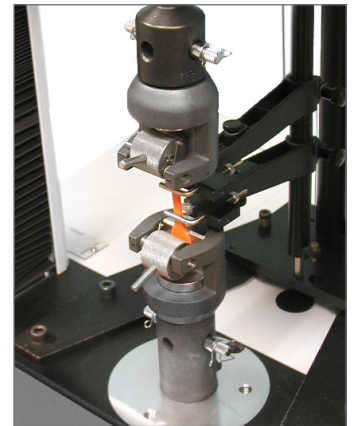
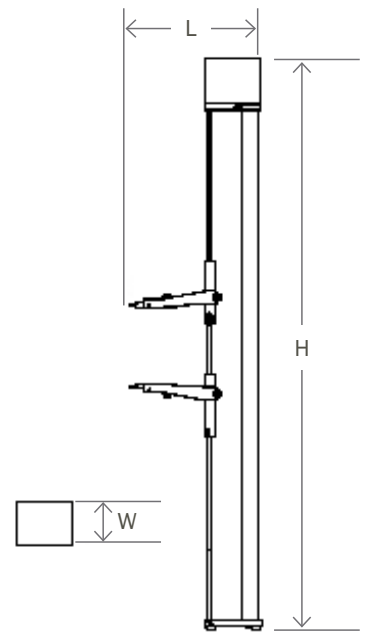

Rubber test on a dual column



Rubber test on a single column

www.instron.com



Worldwide Headquarters
825 University Ave, Norwood, MA 02062-2643, USA
Tel: +1 800 564 8378 or +1 781 575 5000

European Headquarters
Coronation Road, High Wycombe, Bucks HP12 3SY, UK
Tel: +44 1494 464646